



Conventional Flue Log Effect Stove Range with Thermostatic Remote Control

Installation Instructions

IMPORTANT

THE OUTER CASING, FRONT AND GLASS PANEL BECOME EXTREMELY HOT DURING OPERATION AND WILL RESULT IN SERIOUS INJURY AND BURNS IF TOUCHED. IT IS THEREFORE RECOMMENDED THAT A FIREGUARD COMPLYING WITH BS 8423 (LATEST EDITION) IS USED IN THE PRESENCE OF YOUNG CHILDREN, THE ELDERLY OR INFIRM.

This product contains a Heat resistant glass panel. This panel should be checked during Installation and at each servicing interval. If any damage is observed on the front face of the glass panel (scratches, scores, cracks or other surface defects), the glass panel must be replaced and the appliance must not be used until a replacement is installed. Under no circumstances should the appliance be used if any damage is observed, the glass panel is removed or broken.

It is essential that ALL of the screws that retain the glass frame are replaced and tightened correctly. Under no circumstances should the appliance be operated if any of these screws are loose or missing.

These Instructions must be left with the appliance for future reference and for consultation when servicing the appliance. Please make the customer aware of the correct operation of the appliance before leaving these instructions with them.

The commissioning sheet found on Page 3 of this Instruction manual must be completed by the Installer prior to leaving the premises.

CONTENTS

LOFT FREESTANDING - CONVENTIONAL FLUE

Covering the following models:

MODEL	LOFT
Nat Gas	548-006
LPG	548-443

Appliance Commissioning Checklist	3
User Instructions	4
Installation Instructions	12
Site Requirements	12
Technical Specifications	15
Installation	18
Commissioning	32
Servicing Requirements	33
Fault Finding	33
How to replace parts	35
Spare parts list	46
Information Requirement - Gas Heaters	48
Service Records	50

WARNING



In the event of a gas escape or if you can smell gas, please take the following steps:

- Immediately turn off the gas supply at the meter/emergency control valve
- Extinguish all sources of ignition
- Do not smoke
- Do not operate any electrical light or power switches (On or Off)
- Ventilate the building(s) by opening doors and windows
- Ensure access to the premises can be made

Please report the incident immediately to the National Gas Emergency Service Call Centre on 0800 111 999 (England, Scotland and Wales) , 0800 002 001 (N. Ireland) or in the case of LPG, the gas supplier whose details can be found on the bulk storage vessel or cylinder.

The gas supply must not be used until remedial action has been taken to correct the defect and the installation has been recommissioned by a competent person.



It is a requirement of the Building Regulations 2010 that the installation of this appliance is notified to the Local Authority. It is the responsibility of the GasSafe registered installer to carry out this notification to the Local Authority via the GasSafe register Competent Persons Scheme in England and Wales (different rules apply in Scotland and Northern Ireland).

When the installation has been notified, GasSafe will send a Building Regulations Compliance Certificate to you containing details of the work completed. Please ensure that the person responsible for the installation of this appliance completes this notification and records it in the Appliance Commissioning Checklist on page 3.

IT IS YOUR RESPONSIBILITY TO COMPLY WITH THE BUILDING REGULATIONS AND BE ABLE TO PRODUCE THIS CERTIFICATE SHOULD IT BE REQUIRED IN THE FUTURE.

APPLIANCE COMMISSIONING CHECKLIST

To assist us in any guarantee claim please complete the following information:-

IMPORTANT NOTICE

Explain the operation of the appliance to the end user, hand the completed instructions to them for safe keeping, as the information will be required when making any guaranteed claims.

FLUE CHECK	PASS	FAIL
1. Flue Is correct for appliance		
2. Flue flow Test		
3. Spillage Test		
GAS CHECK		
1. Gas soundness & let by test		
2. Standing gas pressure	mb	
3. Appliance working pressure (on High Setting) Minimum Pressure Requirement: NG - 17.5mbar LPG - 34.5mbar NB All other gas appliances must be operating on full	mb	
4. Gas rate	m ³ /h	
5. Does Ventilation meet appliance requirements		
SAFETY CHECK		
1. Check soundness of the Thermocouple connections - including tightness and lead integrity		
2. Glass checked to ensure no damage, scratches, scores or cracks		
3. Glass frame secured correctly and all screws replaced		
BUILDING CONTROL NOTIFICATION		
	YES	NO
1. Installer notified GasSafe/Local Authority of installation via Competent Persons Scheme?		

RETAILER AND INSTALLER INFORMATION

Retailer	Installation Company
.....
.....
Contact No.	Engineer
Date of Purchase	Contact No.
Model No.	GasSafe Reg No.
Serial No.	Date of Installation
Gas Type	

USER INSTRUCTIONS

GENERAL

Installation and servicing must only be carried out by a competent person whose name appears on the GasSafe register. To ensure the engineer is registered with GasSafe they should possess an ID Card carrying the following logo:



In all correspondence, please quote the appliance type and serial number which can be found on the data badge located at the rear of the appliance or on the Commissioning Checklist on Page 3.

Do not place curtains above the appliance:
You must have 300mm clearance between the appliance and any curtains at either side.

The manufacturer considers the full outer casing of this stove to be a working surface and it will become hot whilst in operation. A suitable guard is recommended to protect young children, the aged and the infirm.

No furnishings or other objects should be placed within 1 metre of the front of the appliance.

If a shelf is fitted, a distance of 225mm above the appliance is required.

Do not attempt to burn rubbish in this appliance.

This appliance must only be operated with the door secured firmly in position. If any cracks appear in the glass the appliance must not be used until the glass panel is replaced.

If, for any reason, the flue has to be removed from the appliance, the seals must be replaced in the inner spigot.

Do not obstruct the flue terminal in any way i.e. by planting flowers, trees shrubs etc. in the near vicinity, or by leaning objects up against the terminal guard.

Do not put any objects on the terminal guard; it will lose its shape.

Do not use a garden sprinkler or hose near the terminal.

This product is guaranteed for 5 years from the date of installation, as set out in the terms and conditions of sale between Gazco and your local Gazco retailer. Please consult with your local Gazco retailer if you have any questions. In all correspondence always quote the Model Number and Serial Number.

OPERATING THE APPLIANCE



IMPORTANT: YELLOW FLAMES TYPICALLY APPEAR WHEN THE APPLIANCE HAS REACHED NORMAL OPERATING TEMPERATURE. THIS CAN TAKE UP TO 30 MINUTES.

1

Mode Settings
See Advanced Controls
instructions

2

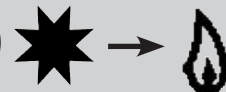

3



4



5



WARNING: IF THE APPLIANCE FAILS TO LIGHT OR BECOMES EXTINGUISHED IN USE, WAIT 3 MINUTES BEFORE ATTEMPTING TO RELIGHT.

ADVANCED CONTROLS

There are 3 different modes available for controlling and operating the appliance:

1. Manual Mode
2. Temp Mode (Automatic)
3. Timer Mode (Automatic)

In **MANUAL MODE** you can:

- turn on the main burner using the UP button
- regulate the flame from high to low and back
- turn off the burner leaving just the pilot burning

In **TEMP MODE (Automatic)** you can:

- set the room temperature so the thermostat in the remote automatically maintains that temperature

In **TIMER MODE (Automatic)** the appliance:

- turns on and off according to the set time periods
- automatically regulates the room temperature during the set periods

i **NOTE: When operating the appliance in Temp or Timer mode, the pilot remains lit and the appliance then automatically switches on at programmed times to bring the room to the set temperature whether or not you are in the room. NEVER LEAVE ANY COMBUSTIBLE MATERIALS WITHIN 1 METRE OF THE FRONT OF THE APPLIANCE.**

SWITCHING BETWEEN MODES

Press the SET button to change to Temperature Mode. Press again to change to Timer Mode. Keep pressing to run through all operating modes. These are:

- MAN
- DAY TEMP
- NIGHT TEMP
- TIMER

and back to MAN

NOTE: MAN mode can also be reached by pressing either the UP or DOWN button.

MANUAL MODE

Press the OFF button and the UP button simultaneously. You hear several clicks and audible beeps as the appliance begins the ignition process, (up to 30 seconds).

Turning the appliance Off:

Press the OFF button to turn the appliance off.

FOR SAFETY, YOU MUST WAIT 30 SECONDS BEFORE LIGHTING THE APPLIANCE AGAIN.

Increasing the Flame Height:

Press the UP button once to increase flame height one stage. Press and hold the UP button to increase to maximum.

Decreasing the Flame Height:

Press the DOWN button once to decrease flame height one stage. Press and hold the DOWN button to decrease to minimum. At the lowest point the appliance goes to 'Standby Mode' (Only Pilot lit).

i **NOTE: While pressing a button a symbol indicating transmission appears on the display. The receiver confirms transmission with a sound signal.**

TEMP MODE (AUTOMATIC)

The display shows the current **room** temperature.

To increase or decrease the appliance's output:

Press the SET button to select either the DAY TEMP or the NIGHT TEMP mode by briefly pressing the SET button.

Hold the SET button until the TEMP display flashes and then let go.

Set the desired temperature with the UP and DOWN arrows. (Minimum temperature 5C, maximum 40C or 40F to 99F when Fahrenheit is the preferred option)

Press the OFF button to stop the display flashing or wait to return to TEMP mode.

i **NOTE: If you set a temperature that is beneath the current room temperature, the appliance automatically switches to PILOT (Stand by).**

If you would like the Night temperature control to turn off then decrease the temperature until [-] is displayed.

TIMER MODE (AUTOMATIC)

There are two programmable settings you can make over a 24 hour period, P1 and P2. These are normally used to provide an early morning and evening setting for each working week:

- P1 + ● = Start Timed Setting 1
- P1 + ☺ = End of Timed Setting 1
- P2 + ● = Start Timed Setting 2
- P2 + ☺ = End of Timed Setting 2

P1 - Program 1 for a Timed Setting

Press the SET button until the TIMER mode is displayed.

Hold the SET button. The displays flashes the current time for P1. **While the time displayed is flashing you can alter the hours and minutes set.**

To set the time your appliance first lights, change P1 ●

- Press the UP button to alter the hour.
- Press the DOWN button to alter the minutes in 10 minute increments.

Press SET again to move to the end setting for P1 ☺ This is the time your appliance first shuts down:

- Press the UP button to alter the hour.
- Press the DOWN button to alter the minutes.

P2 - Program 2 for a Timed Setting

Use the same steps outlined in 2.8 to change the setting for P2. If you have already set P1 and want to alter the setting for P2 only:

- Press the SET button until TIMER mode is displayed.
- Hold the SET button **until the display flashes the current time** for P1●
- Press the SET button once again to scroll past the settings for P1● and P1

With the time still flashing:

- Press the UP button to alter the hour
- Press the DOWN button to alter the minutes

Once all four times are set press the OFF button.

To view existing settings:

- Select Timer Mode
- Press and briefly hold the SET button you see the start time for P1.
- Repeat the above step for the start and end of each program.

Low Battery

“BATT” is displayed on the remote when its batteries need replacement.

Setting the time

Simultaneously press the up and down buttons.

Press the up button to set the hour and the down button to set the minutes.

Press OFF to return to the manual mode or simply wait.

Setting the °C/24 Hour or °F/12 Hour clock

Press OFF and the down arrow until the display changes from °C/24 hour clock to °F/12 hour clock and vice versa.

 **If the remote is removed, lost or damaged, signals transmitted to the receiver cease. Your appliance will go to standby (pilot) mode after 6 hours.**

TROUBLESHOOTING



IMPORTANT: In the unlikely event that the handset fails to communicate correctly with the appliance it may be necessary to turn off the gas supply at the isolation valve until any problems can be resolved.

The gas meter and isolation valve can be located outside in a meter box, under the stairs, beneath the kitchen sink or in the garage. Whilst this list is not exhaustive, it is important to be able to identify the location of the valve in case of any gas emergency.

To turn off the gas supply, simply turn the handle so the lever is at 90 degrees to the upright gas pipe.

If you smell gas, open doors and windows and never operate any electrical switches. Immediately call the Gas Emergency Services on 0800 111 999.

CLEANING THE APPLIANCE



IMPORTANT: THE OUTER PANNELLING OF THE GAZCO LOFT IS MADE FROM CAST IRON. USE CAUTION WHEN INSTALLING, REMOVING AND STORING AS THE COMPONENTS ARE HEAVY AND SHOULD BE HANDLED CAREFULLY.

Make sure the fire and surrounds are cool before cleaning.

- Use:
- A dry cloth to clean the appliance casting.
 - A damp cloth for the glass front.

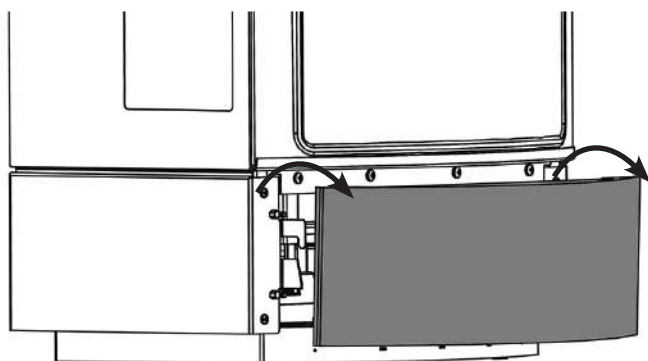
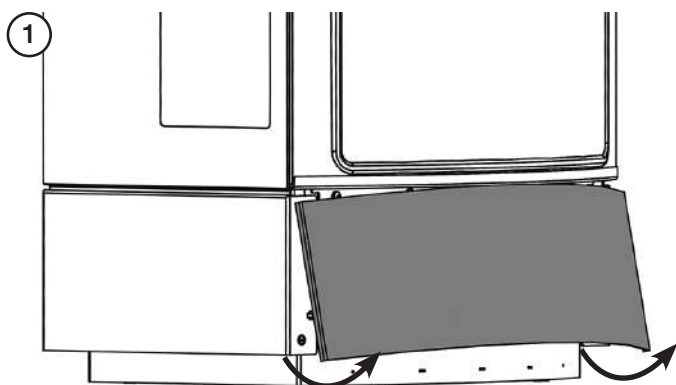
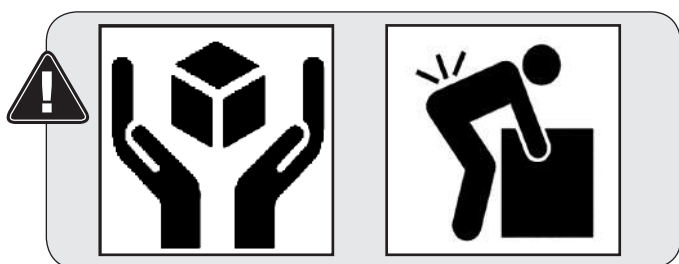

2

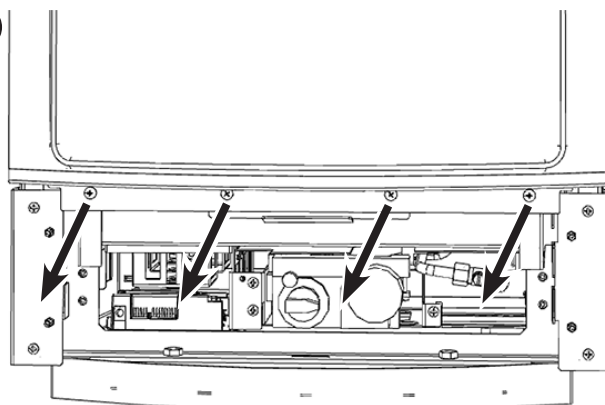

3

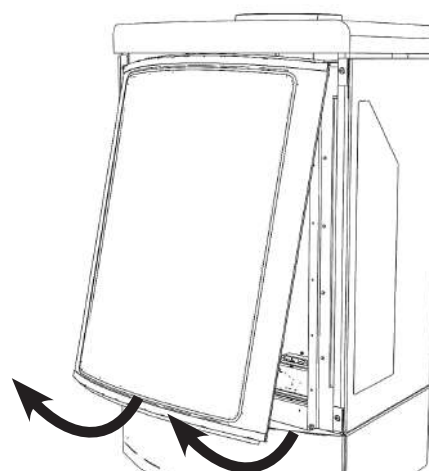

NOTE: SUPPORT DOOR WHEN REMOVING

Replace ALL of the securing screws ensuring that a screw is present in all fixing slots.



UNDER NO CIRCUMSTANCES SHOULD THE APPLIANCE BE USED IF ANY OF THE GLASS FRAME RETAINING SCREWS RE LOOSE OR MISSING.

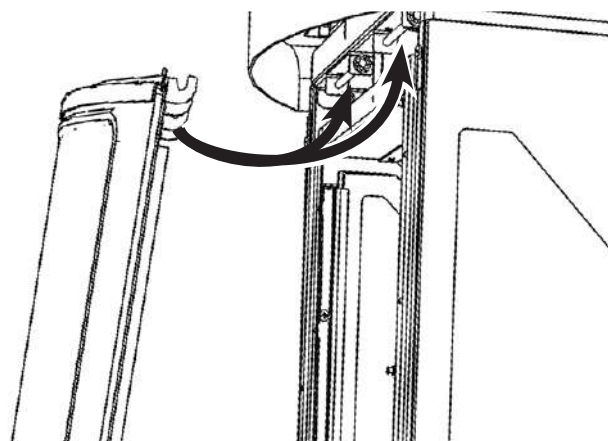

CHANGING THE APPLIANCE BATTERIES



It is essential to use high quality batteries (Duracell or equivalent) when replacing batteries in the handset or control box.

1

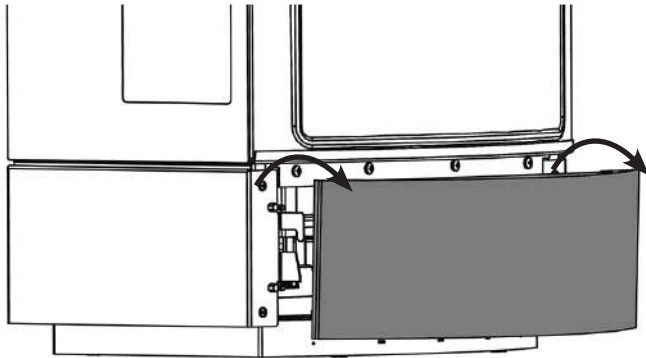
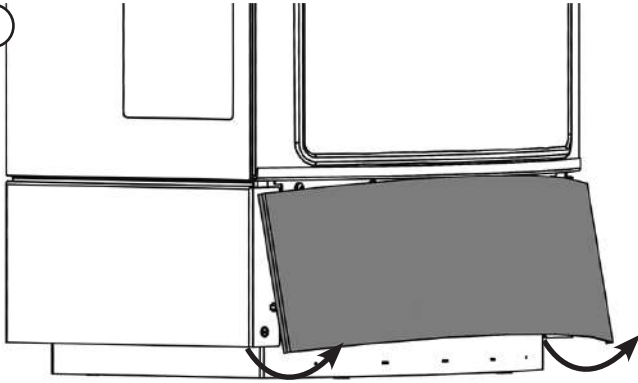

2

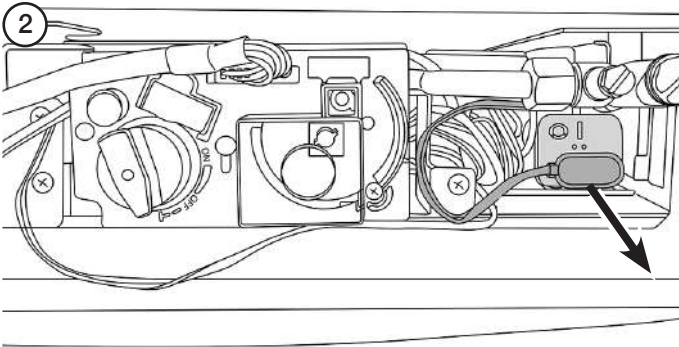

3

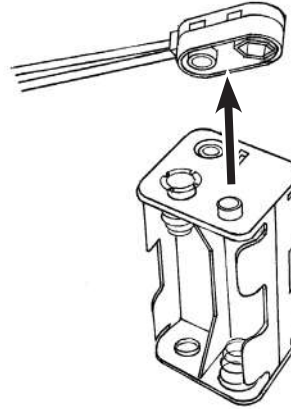

4 X AAA



PLEASE ENSURE NO WIRES ARE TRAPPED BEFORE REPLACING THE PLINTH. THE LEAD IS EASILY DAMAGED.

LOG LAYOUT

LOGS MUST BE POSITIONED ACCORDING TO THE FOLLOWING INSTRUCTIONS TO GIVE THE CORRECT FLAME EFFECT.

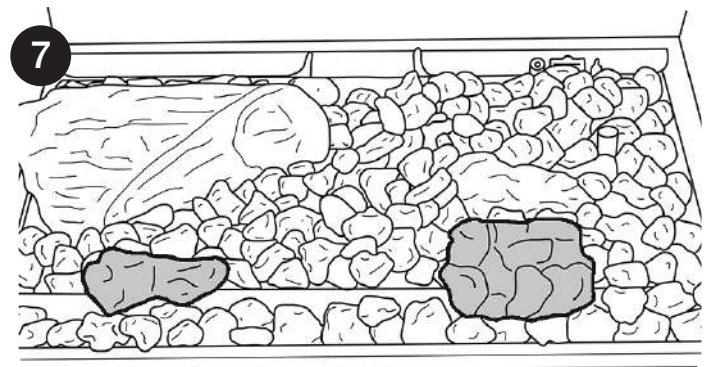
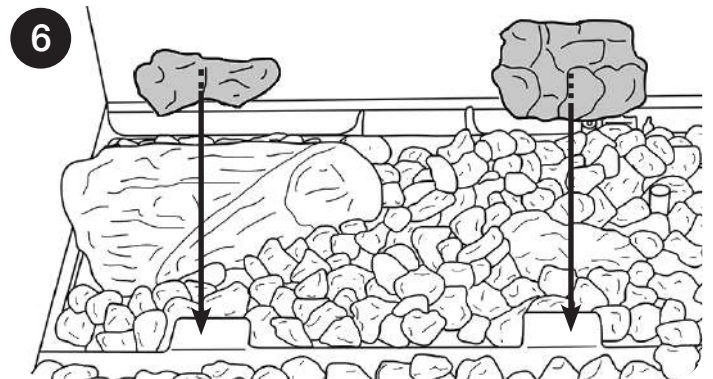
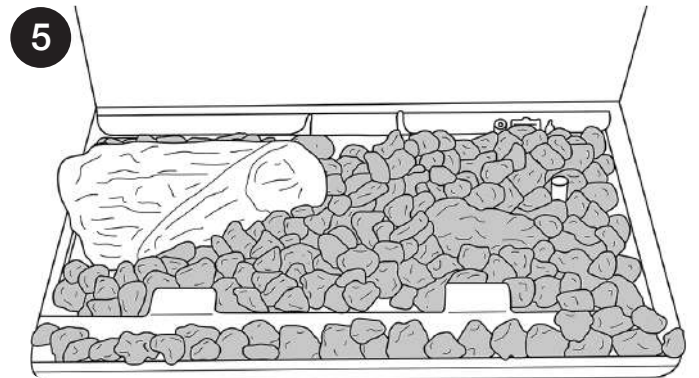
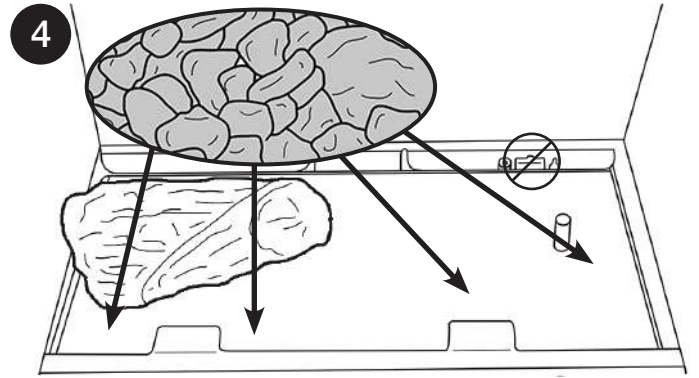
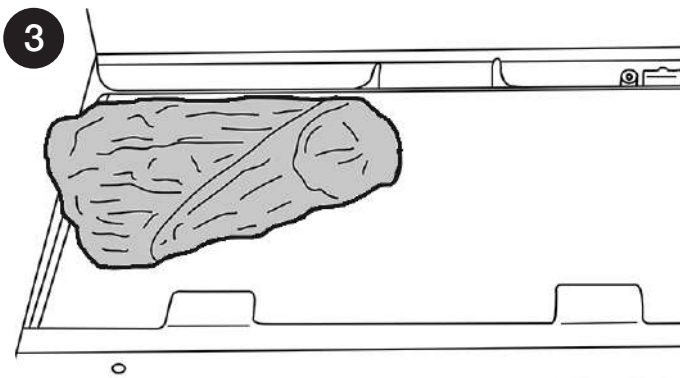
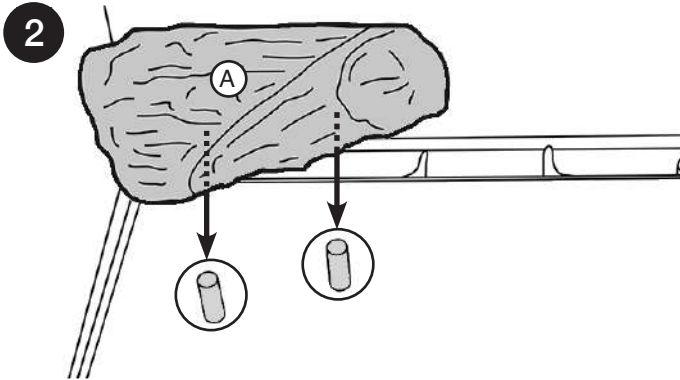
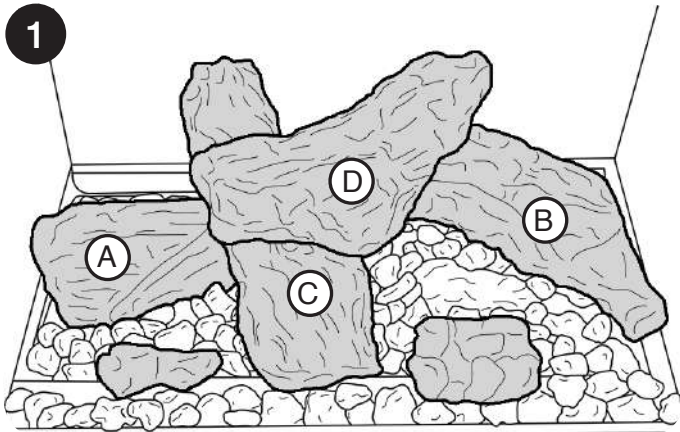

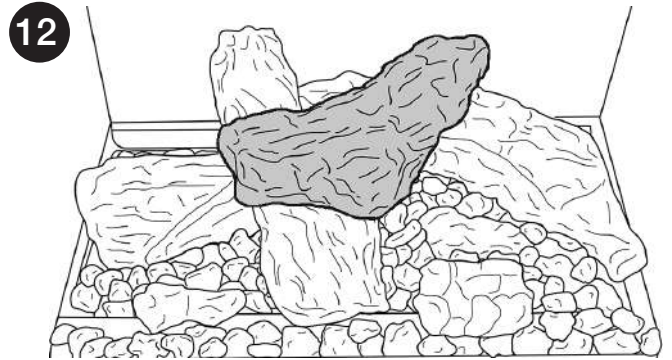
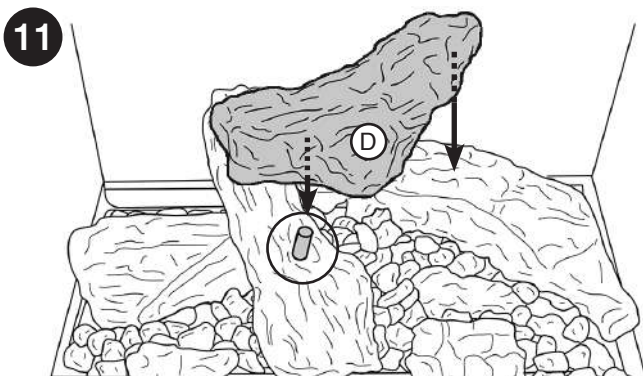
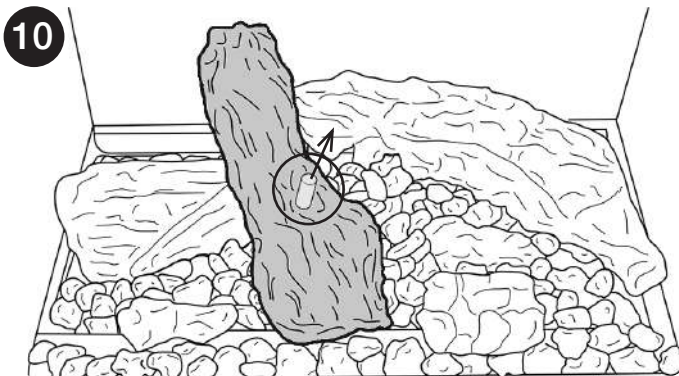
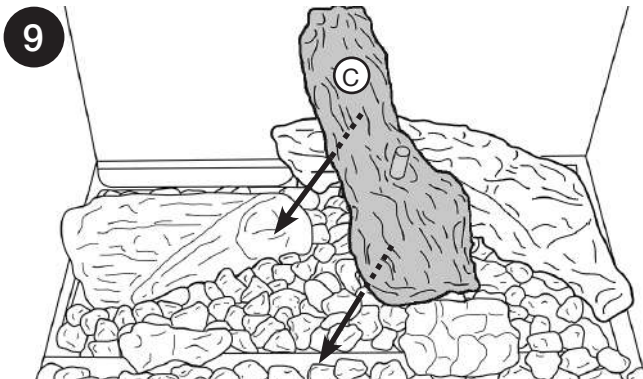
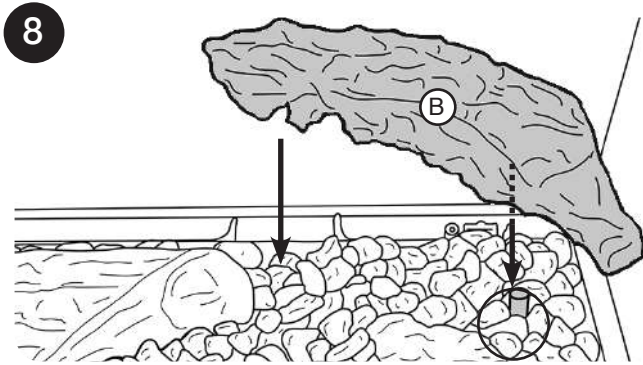

! IT MAY NOT BE NECESSARY TO USE ALL THE EMBAGLOW IN THIS PACK. SPARINGLY SPREAD AN AMOUNT OF THE FIBRES PROVIDED ON THE SECTIONS HIGHLIGHTED IN THE INSTRUCTIONS. Take care not to use more than specified in the instructions.

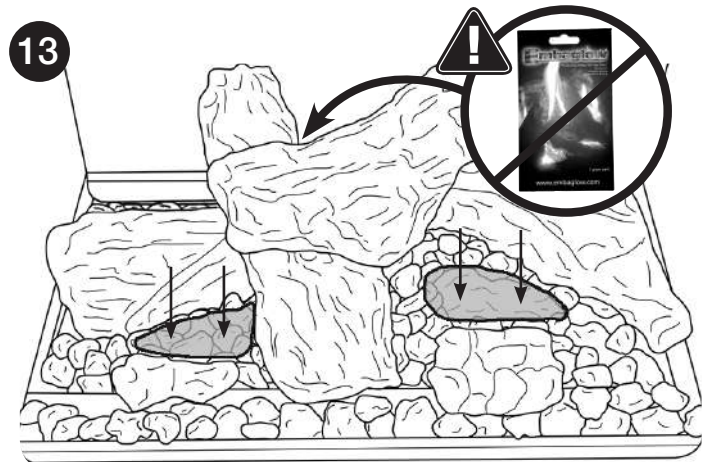

WARNING:
DO NOT PLACE NEAR THE PILOT AREA.
 Do not place Embaglow in the area around the pilot burner - see highlighted example on diagram as this may effect the ignition process and flame picture.

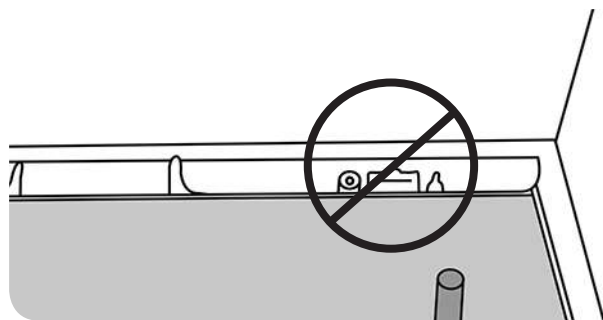

FLUE SURE SYSTEM

The appliance is fitted with the Gazco Flue Sure System, which will act to cut off the gas supply to the burners in the event of incorrect operation of the flue. If the system acts to cut off the gas supply, this indicates that there is insufficient flue pull. If this occurs a minimum of 10 minutes should be allowed before trying to relight. Continued operation of this safety device means there may be a serious problem with the flue system. A qualified GasSafe engineer should inspect this.

DO NOT USE THE APPLIANCE UNTIL AN ENGINEER SAYS IT IS SAFE TO DO SO.

FLAME FAILURE DEVICE

This is a safety feature incorporated on this appliance which automatically switches off the gas supply if the pilot goes out and fails to heat the thermocouple.

IF THIS OCCURS DO NOT ATTEMPT TO RELIGHT THE APPLIANCE FOR 3 MINUTES.

RUNNING IN

During initial use of a new Gazco appliance a strong odour will be encountered as various surface coatings become hot for the first time. Although these odours are harmless it is recommended that the appliance is operated on maximum for 4 to 8 hours in order to fully burn off these coatings. After this period the odours should then disappear.

If the odours persists, please contact your installer for advice.

During the first few hours of burning there may be discolouration of the flames. This will also disappear after a short period of use.

SERVICING AND SUPPORT



Servicing and Support

To keep your appliance looking and performing at its best, it must be serviced annually. This service must be undertaken by a suitably qualified individual and your retailer can organise this for you. Alternatively, Gazco offer a manufacturers premium service with our friendly team of qualified engineers which can be booked at www.gazco.com/support

In all correspondence always quote the Model number and the Serial number which may be found on the Commissioning Checklist (Page 3).

VENTILATION

Any purpose provided ventilation should be checked periodically to ensure that it is free from obstruction.

INSTALLATION DETAILS

Your installer should have completed the commissioning sheet at the front of this book. This records the essential installation details of the appliance. In all correspondence always quote the Model number and Serial number.

HOT SURFACES

Parts of this appliance become hot during normal use. Regard all parts of the appliance as a 'working surface', except for the access to the controls.

Provide a suitable fire guard to protect young children, the elderly and infirm.

INSTALLATIONS INSTRUCTIONS

SITE REQUIREMENTS

SAFETY PRECAUTIONS

This appliance must be installed according to local and national codes of practice. Failure to install the appliance correctly could lead to prosecution. **Read these instructions before installing and using this appliance.**

These instructions must be left intact with the user.

Do not attempt to burn rubbish on this appliance.

Keep all plastic bags away from young children.

Do not place any object on or near to the appliance and allow adequate clearance above the appliance.

IF THE APPLIANCE IS EXTINGUISHED OR GOES OUT IN USE, WAIT 3 MINUTES BEFORE ATTEMPTING TO RELIGHT THE APPLIANCE.



IMPORTANT: REFER TO DATA BADGE AND TECHNICAL SPECIFICATION AT THE FRONT OF THE MANUAL TO ENSURE THE APPLIANCE IS CORRECTLY ADJUSTED FOR THE GAS TYPE AND CATEGORY APPLICABLE IN THE COUNTRY OF USE.

FOR DETAILS OF CHANGING BETWEEN GAS TYPES REFER TO SERVICING INSTRUCTIONS.

FLUE & CHIMNEY REQUIREMENTS

WHEN INSTALLING A FLUE SYSTEM PLEASE REFER TO THE MANUFACTURERS INSTRUCTIONS.

The European chimney standards now describe chimneys and flues by their temperature, pressure and resistance to corrosion, condensation and fire. To identify the correct flue system, the minimum flue specification is shown in the Technical Specification. Existing chimneys are not covered by this system.

The chimney or flue system must comply with the rules in force, and must be a minimum of 127mm (5") in diameter.

A 5" (127mm) liner must be used if fitting the appliance into an existing brick built chimney.

Larger lined flues can work, but in some instances could cause cold start flue problems resulting in nuisance shutdown. Lined flues above 7" (175mm) are not recommended.

Suitable systems are:

- Flexible liner which must be continuous from the appliance spigot to the roof terminal.
- Gazco Linerless kit.

UNDER NO CIRCUMSTANCES MUST THE LINERLESS KIT BE USED WITH ANY INSTALLATION OTHER THAN AN EXISTING MASONRY CHIMNEY WHICH HAS A MINIMUM DIAMETER OF

178mm (7"). THE CHIMNEY MUST BE SOUND AND CLEAN. IF PREVIOUSLY USED FOR SOLID FUEL, IT MUST BE SWEEP PRIOR TO PROCEEDING WITH THE INSTALLATION.

NOTE: If the Linerless kit is to be used, due care should be taken to prevent condensation forming in the chimney. Do not fit the Linerless Kit if the chimney is taller than 10 metres (external wall) or 12 metres (internal wall).

The minimum flue height for the appliance must be 3 metres (10ft). Any horizontal flue run from the rear outlet must not exceed 100mm from the back of the appliance.

The chimney or flue must be free from any obstruction. Any damper plates must be removed or secured in the fully open position, and no restrictor plates fitted.

The chimney must be swept prior to the installation, but it need not be swept if it can be seen the chimney is clean and unobstructed throughout its entire length.

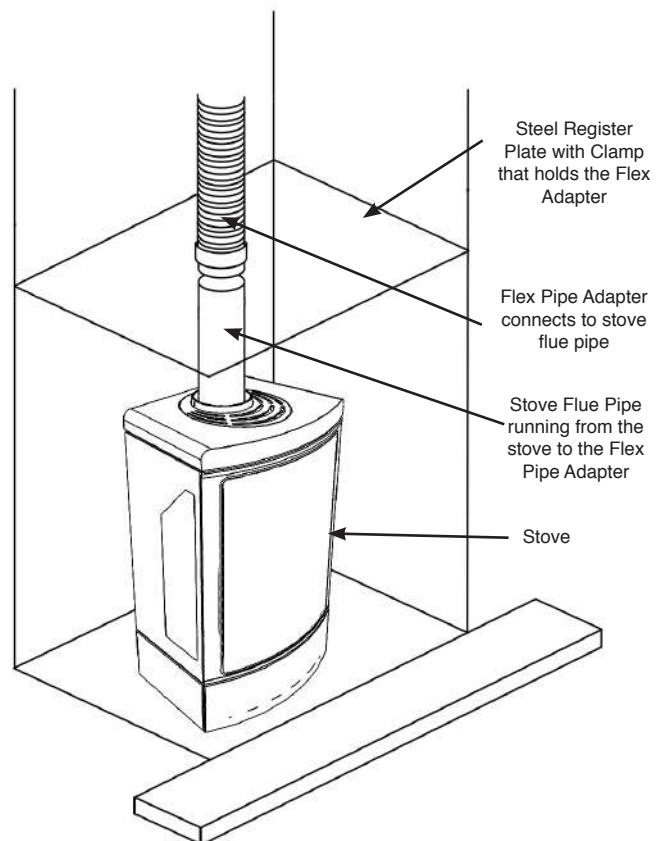

FLUE OPTIONS

Consult the rules in force.

NOTE: This appliance does not normally require any additional ventilation when installed in GB.

A range of Vitreous Enamel Gloss Black flue pipe is available to compliment the appliance. Please contact your Gazco retailer for further information.

GAS SUPPLY

THIS APPLIANCE IS INTENDED FOR USE ON A GAS INSTALLATION WITH A GOVERNED METER.

Before installation, ensure that the local distribution conditions (identification of the type of gas and pressure) and the adjustment of the appliance are compatible.

Ensure the gas supply delivers the required amount of gas and is in accordance with the rules in force.

You can use soft copper tubing on the installation and soft soldered joints outside the appliance and below the fire.

A factory fitted isolation device is part of the inlet connection; no further isolation device is required.

All supply gas pipes must be purged of any debris that may have entered prior to connection to the appliance.

The gas supply must be installed in a way that does not restrict the removal of the appliance for servicing and inspection.

VENTILATION

IMPORTANT: Ensure any national ventilation requirements are taken into account during installation of the fire.

UK ONLY:

The appliance has a nominal input not exceeding 7.0kW and does not normally require any additional permanent ventilation.

FOR THE REPUBLIC OF IRELAND REFER TO THE RULES IN FORCE FOR VENTILATION REQUIREMENTS.

APPLIANCE LOCATION

Once the position of the appliance has been decided: Follow the instructions for securing the appliance on Page 20.

The non-combustible hearth must be at least 12mm thick, and project a minimum of 50mm from the base of the appliance in all directions.

The appliance is not suitable for installation against a combustible wall. A combustible side wall must be a minimum of 200mm.

This appliance can be installed with an up and out flue (vertical wall - horizontal flue) or with a vertical flue with roof termination (see Site Requirements, **Flue Options**).

**HEARTH INSTALLATION
(NOT APPLICABLE FOR BASE SECTION INSTALLATIONS**

MODELS)

Building Regulations state this appliance must stand on a non-combustible hearth that is at least 12mm thick and projects 50mm minimum from the base of the appliance in all directions, however Gazco recommend the hearth extends to the following dimensions, see Diagram.

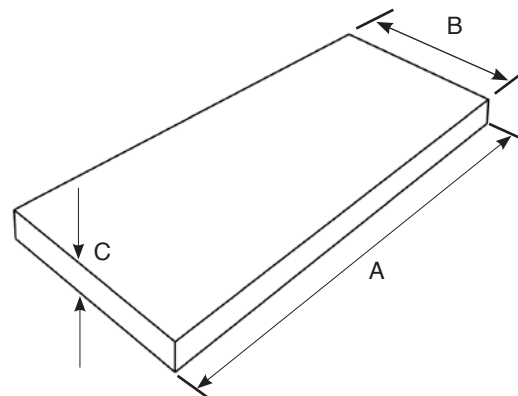

Dimensions	A	B	C
All Models	781mm	498mm	12mm

BASE SECTION INSTALLATION

It is not necessary to site these products on a non-combustible floor. However, for practical reasons, the floor should be flat and solid to allow the appliance to be levelled and secured in place.

This appliance may be situated anywhere in the room, but due consideration should be taken to ensure that it is sited within the constraints of the allowable flue configuration.

DO NOT INSTALL APPLIANCE ON A CARPET.

MINIMUM CLEARANCE

The appliance is not suitable for installation against a combustible wall.

Ensure that all minimum clearances to combustible materials are complied with, see Diagrams.

The specified clearances provide the minimum distance to combustible materials. If the appliance is intended to be installed into a non-combustible opening the clearance to the **sides and above** the appliance can be reduced. However, it is recommended that the specified clearances are maintained irrespective of the materials used in the construction of the opening to allow adequate air flow and access to controls. **The clearance at the rear of the appliance must always be a minimum of 50mm.**

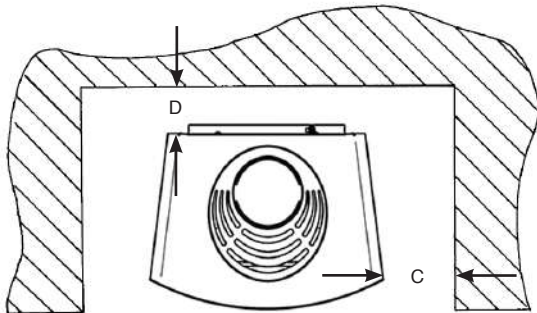
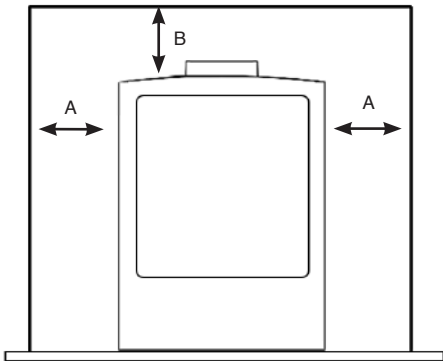

Dimension	Loft
A	200
B	225
C	200
D	50

The above dimensions provide adequate clearance to combustible materials. It may be necessary to add additional clearance so that spillage tests can be performed when necessary.

TECHNICAL SPECIFICATION

MODEL	GAS CAT.	GAS TYPE	WORKING PRESSURE	AERATION	INJECTOR	GAS RATE M ³ /H	INPUT KW (GROSS)		COUNTRY
							HIGH	LOW	
Loft Nat Gas	I ₂ H	G20	20mbar	6mm x 2	360	0.590	6.2	3.5	GB, IE
Loft LPG	I ₃ P	G31	37mbar	13mm x 2	125	0.222	5.9	3.3	
Efficiency Class 1 - 78% Net									
Flue Size TOP/REAR EXIT 127mm ø									
Gas Inlet Connection Size = 8mm ø									
Minimum Flue Specification = T250/N2/O/D/1									
Maximum Flue Temp = 240°C									

i The net efficiency of this appliance has been measured as specified in EN613:2001 and the result after conversion to gross using the appropriate factor from Table E4 of SAP 2012 is 84.9%. The test data has been certified by Kiwa Nederland B.V. The gross efficiency value may be used in the UK Government's Standard Assessment Procedure (SAP) for energy rating of dwellings.

This appliance has been certified for use in countries other than those stated. To install this appliance in these countries, it is essential to obtain the translated instructions and in some cases the appliance will require modification. Contact Gazco for further information.

PACKING CHECKLIST

ALL MODELS	
Qty Description	Fixing Kit containing:-
1 x Loft Appliance 1 x Log Set (4 Logs) 1 x Lining Set	<p>All Models: 2 x No.8 Red Rawl Plugs 1 x Battery Holder 1 x Embaglow Packet 1 x instructions 2 x No.8 Screw 4 x AA Batteries 1 x 9v Battery 1 x 70mm Restrictor</p> <p>Graphite Metal Plinth Only: 3 x M5x25 Hex Head Screws</p> <p>To Extension Section Only: 4 x No.8 x 10 Screws</p> <p>Stone Plinth & Log Store Only: 4 x Metal Rawl Plug 4 x No.6 x 40 Coach Screw 4 x 32mm Felt Pad</p>

DIMENSIONS

STANDARD MODEL

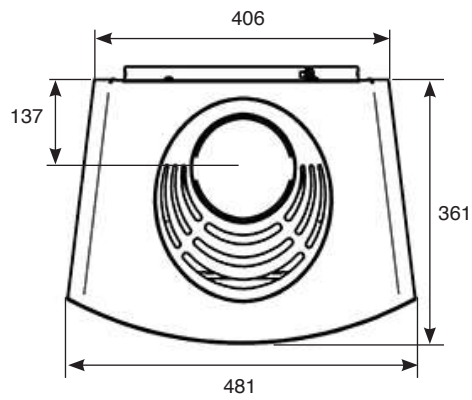
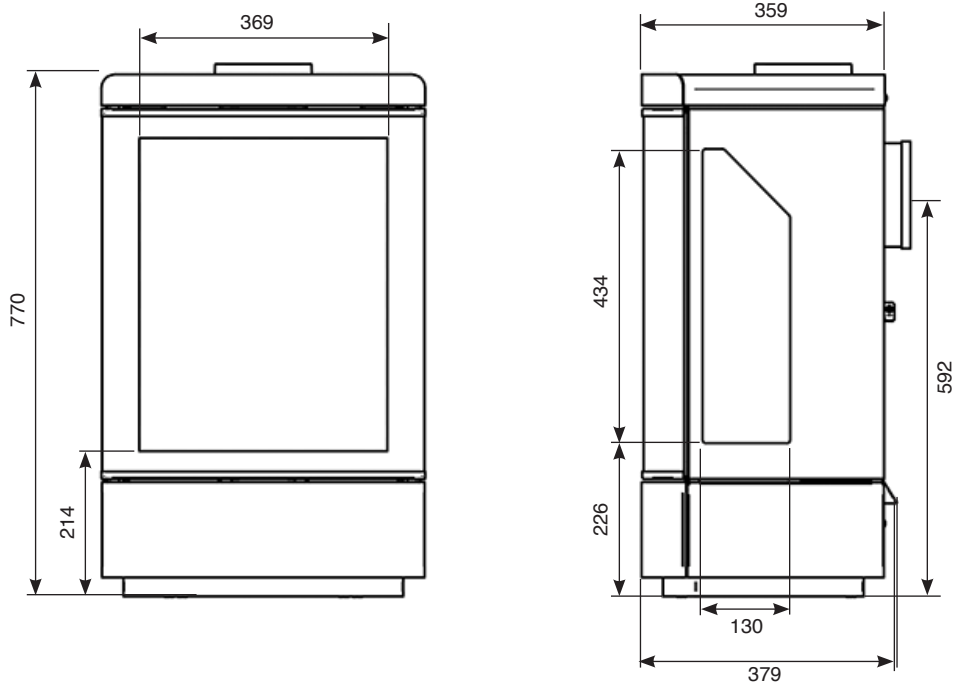

DIMENSIONS

WITH LOG STORE BASE

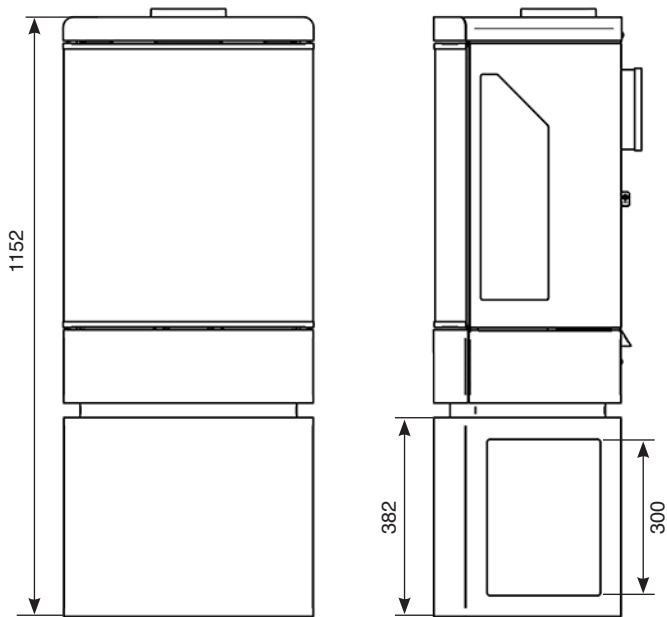

WITH PLINTH

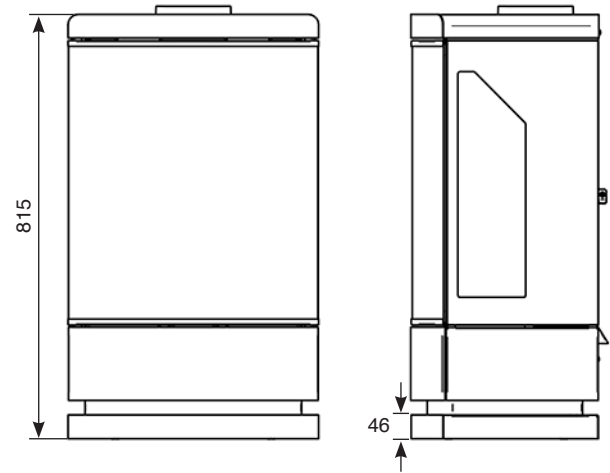

WITH TOP BOX

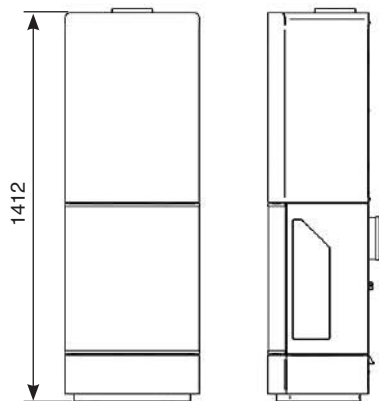

WITH TOP BOX AND PLINTH

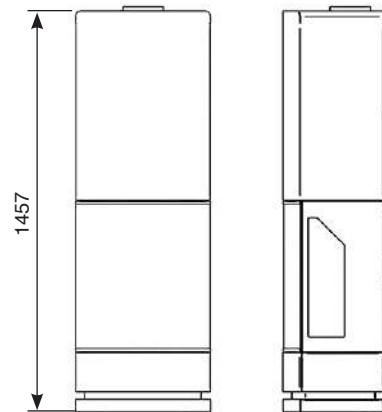

WITH LOG STORE BASE AND TOP BOX

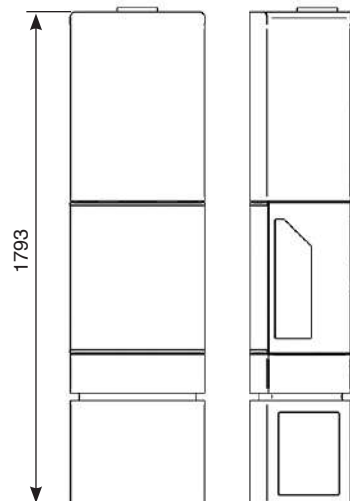

INSTALLATION



IMPORTANT: REFER TO DATA BADGE AND TECHNICAL SPECIFICATION AT THE FRONT OF THE MANUAL TO ENSURE THE APPLIANCE IS CORRECTLY ADJUSTED FOR THE GAS TYPE AND CATEGORY APPLICABLE IN THE COUNTRY OF USE.

FOR DETAILS OF CHANGING BETWEEN GAS TYPES REFER TO SERVICING, SECTION 15, REPLACING PARTS.



IMPORTANT: THE OUTER PANNELLING OF THE GAZCO LOFT IS MADE FROM CAST IRON. USE CAUTION WHEN INSTALLING, REMOVING AND STORING AS THE COMPONENTS ARE HEAVY AND SHOULD BE HANDLED CAREFULLY.

UNPACKING

Remove the appliance from its packaging, and check that it is complete and undamaged.

The cast plate is stored on top of the appliance. Remove and store in a safe place.

Put the loose ceramic parts to one side so that they are not damaged during installation.



Please note: As an optional extra Gazco can provide a mains adapter to supply constant power to the appliance control box instead of the battery pack.

If installing an appliance with the adapter make provision for a mains power socket within 1.5m of the control box and follow the instructions provided.

TOP OR REAR EXIT

The appliance is supplied as a top exit configuration. Before locating the appliance choose the correct flue outlet position.

REAR EXIT

①

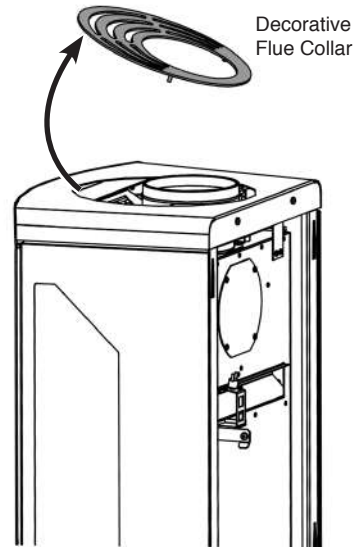

②

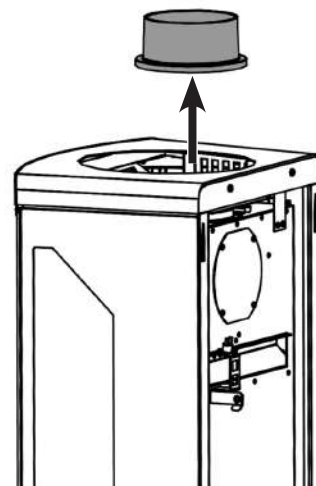

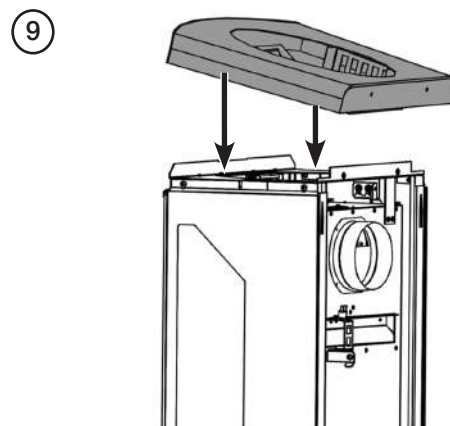
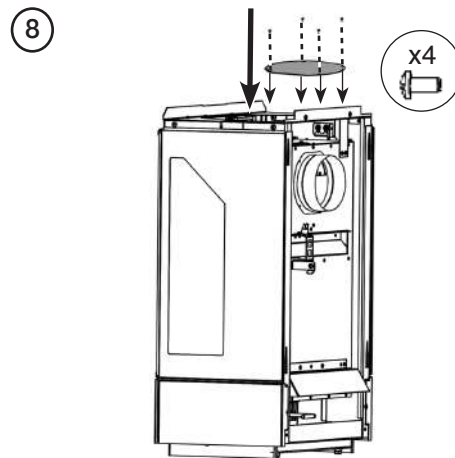
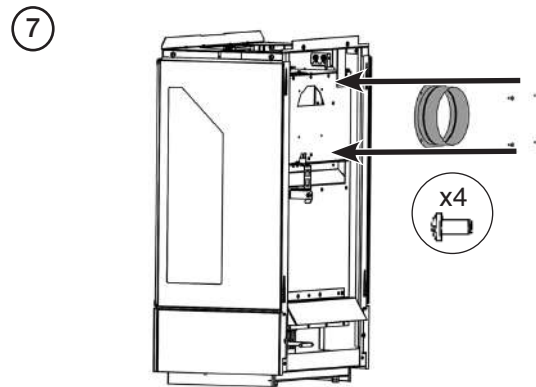
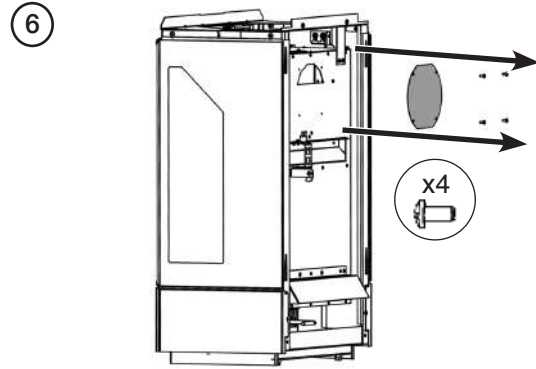
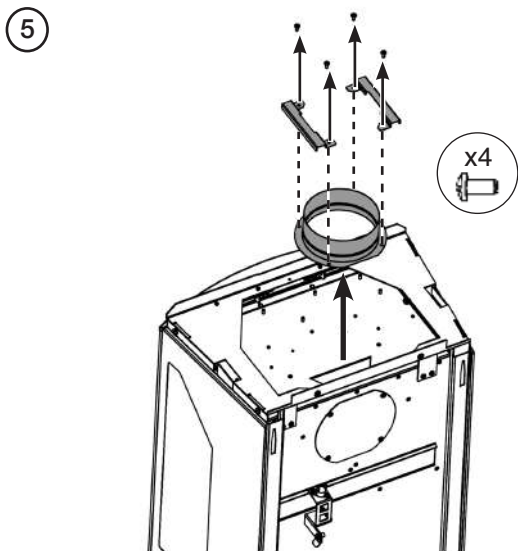
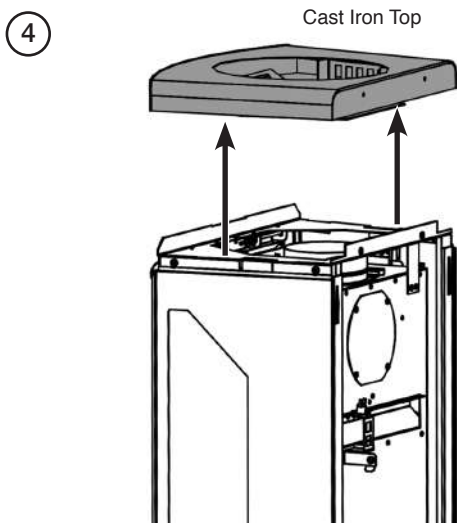
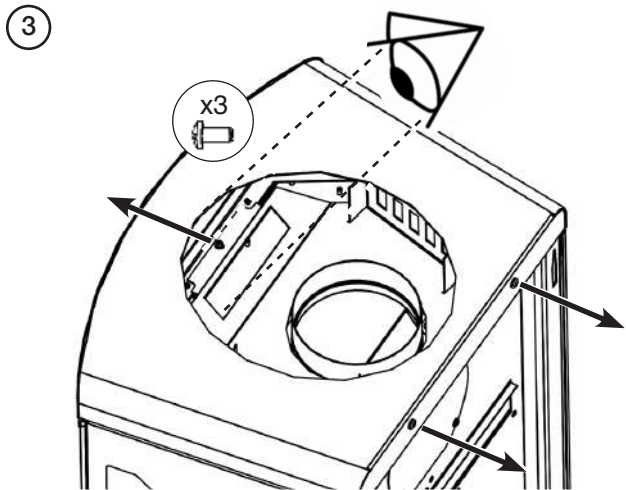

10

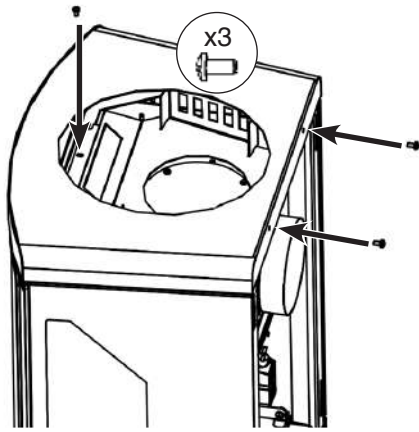

11

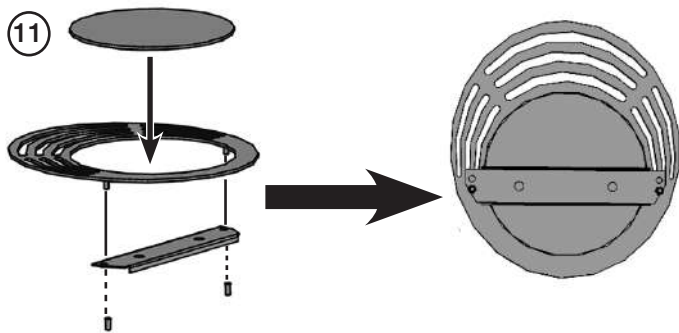

12

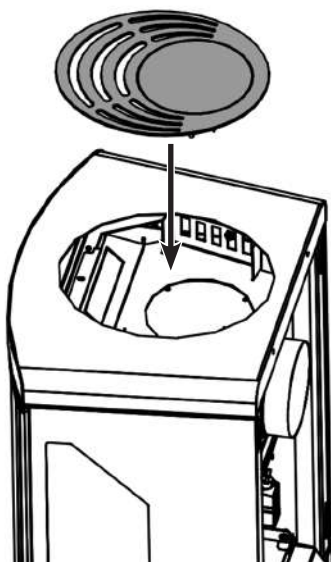

SECURING THE APPLIANCE



IMPORTANT: THE OUTER PANNELLING OF THE GAZCO LOFT IS MADE FROM CAST IRON. USE CAUTION WHEN INSTALLING, REMOVING AND STORING AS THE COMPONENTS ARE HEAVY AND SHOULD BE HANDLED CAREFULLY.

ALL MODELS

1

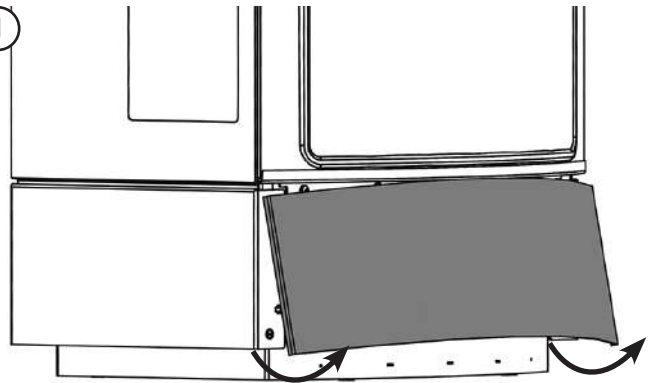

2

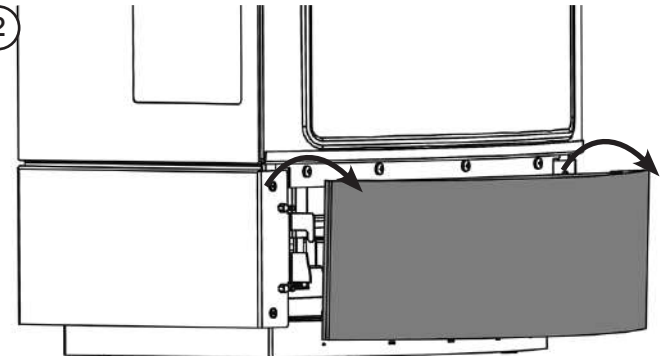

3

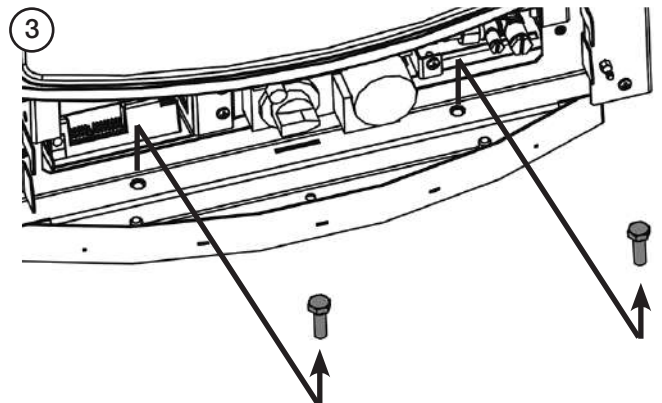

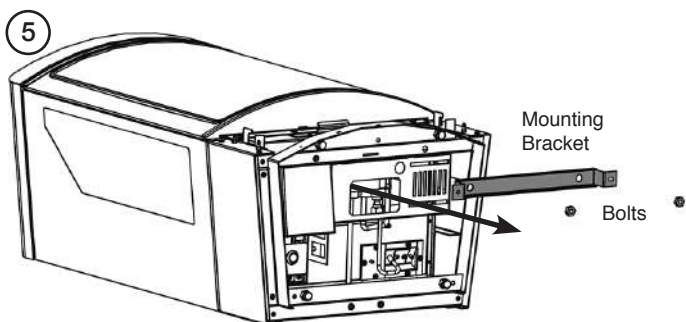
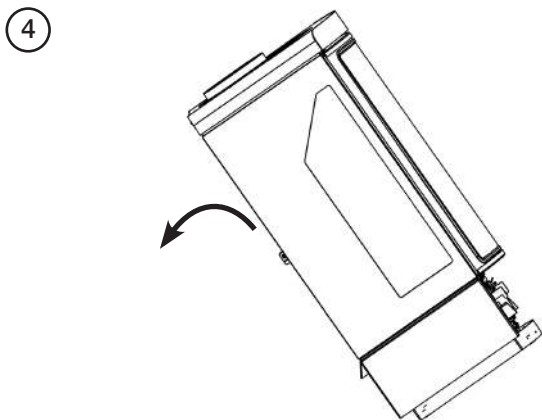

DIRECT TO HEARTH

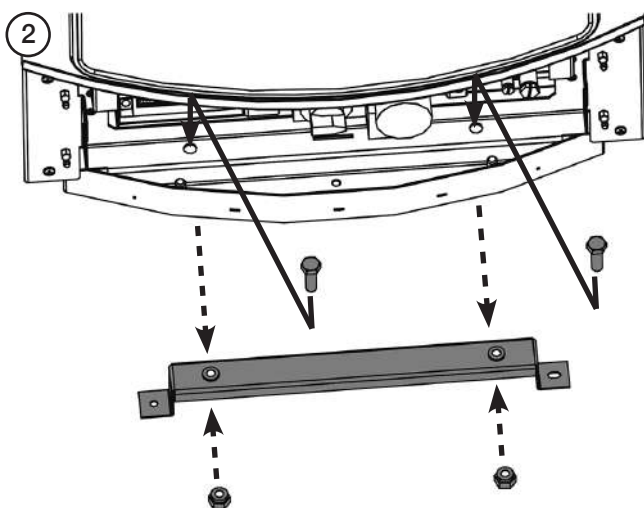

PLINTH FIXING

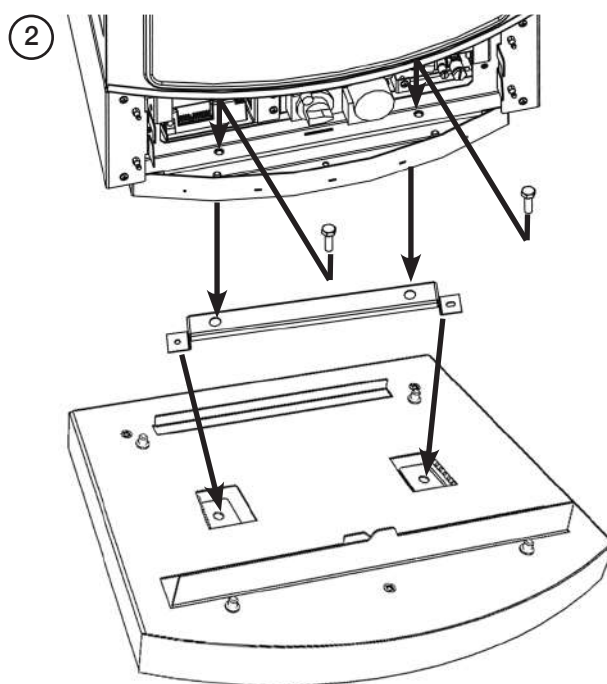
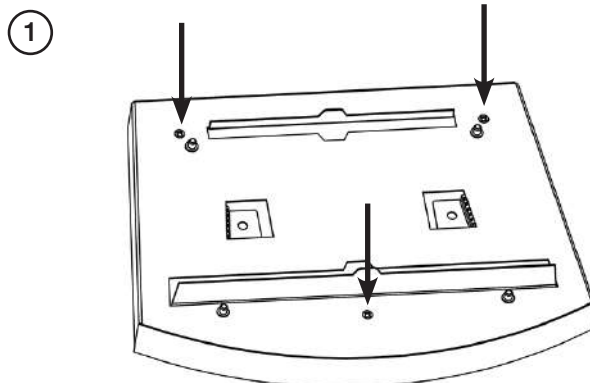

i NOTE: If fitting with a stone plinth it will be necessary to place the screw threads in the fixing holes in the stone and apply felt pads to the underside before siting the appliance.

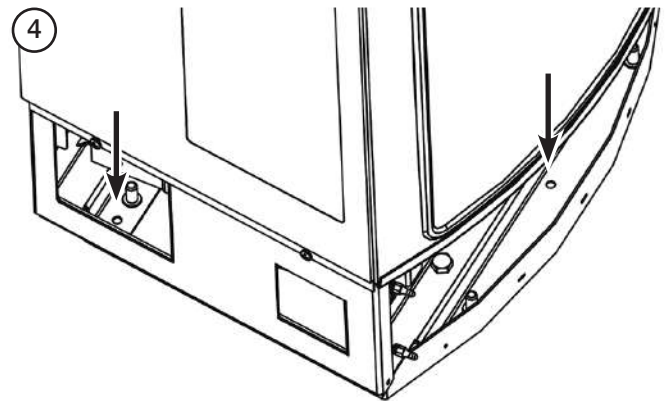
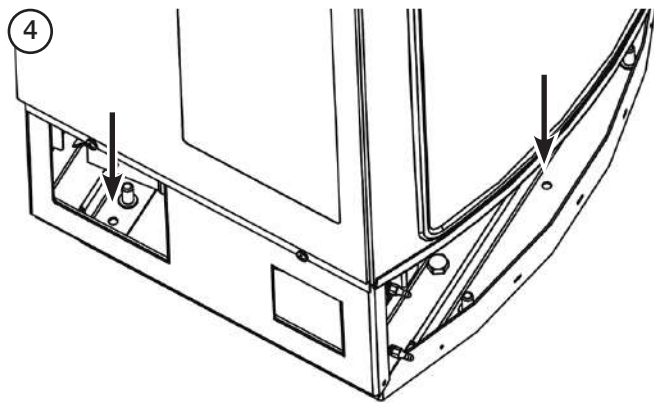
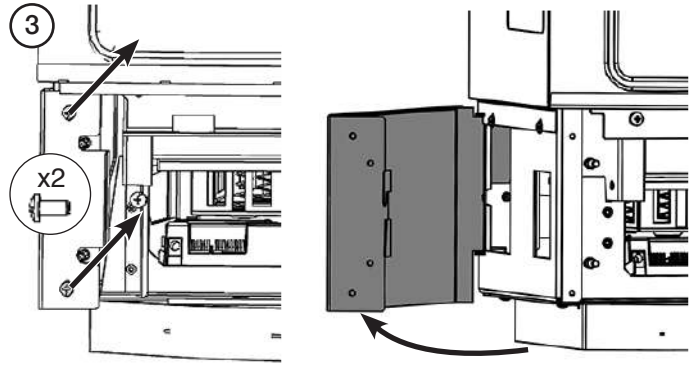
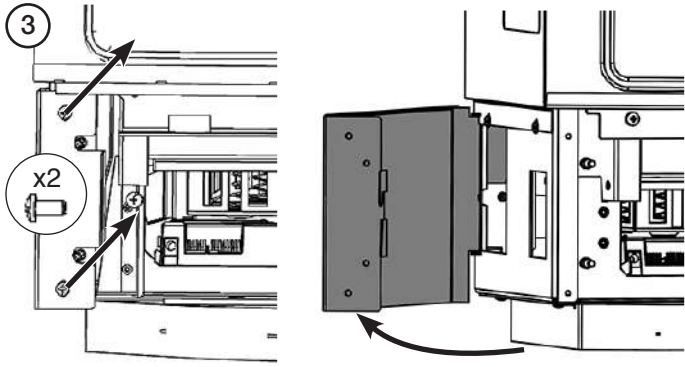

BASE SECTION FIXING

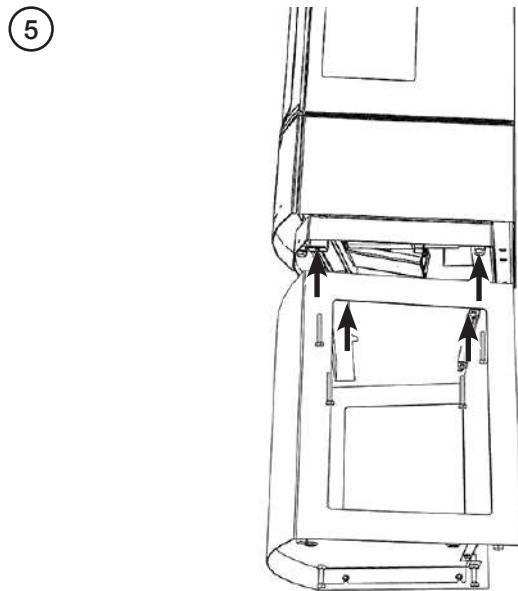
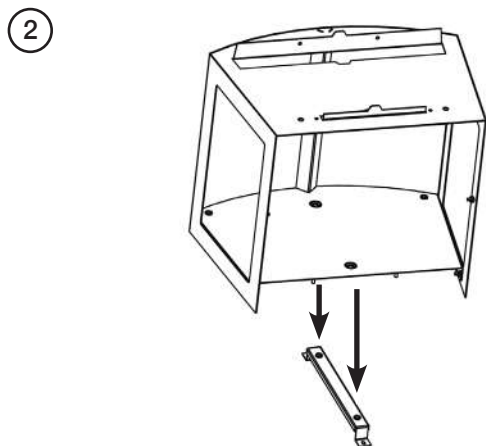
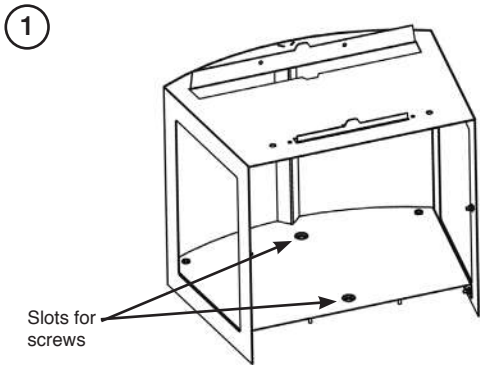

INSTALLATION OF THE TOP BOX

TOP EXIT

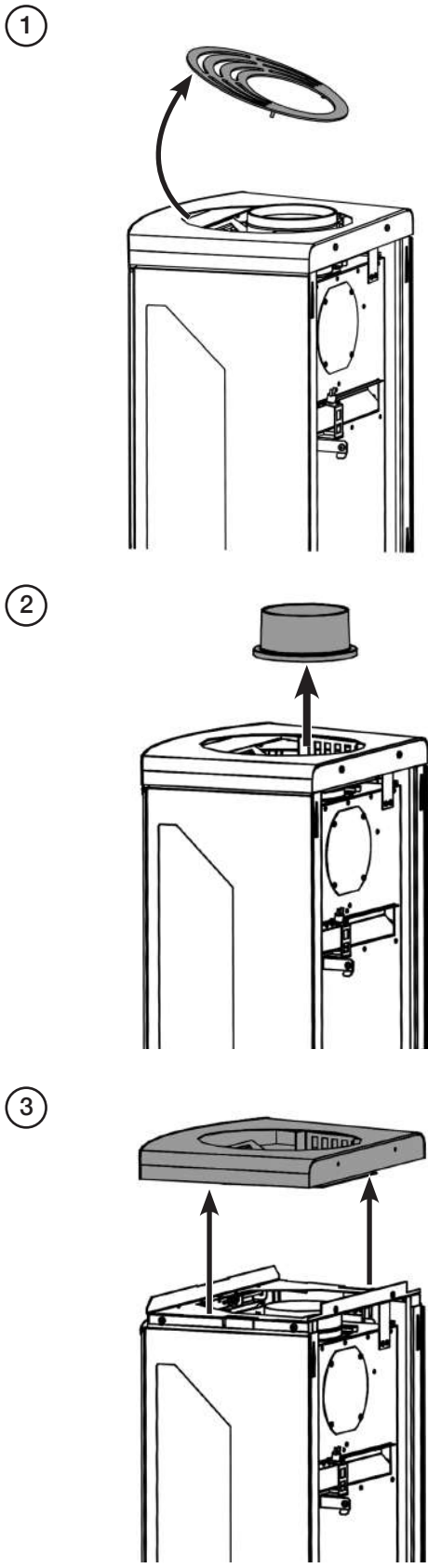

REAR EXIT

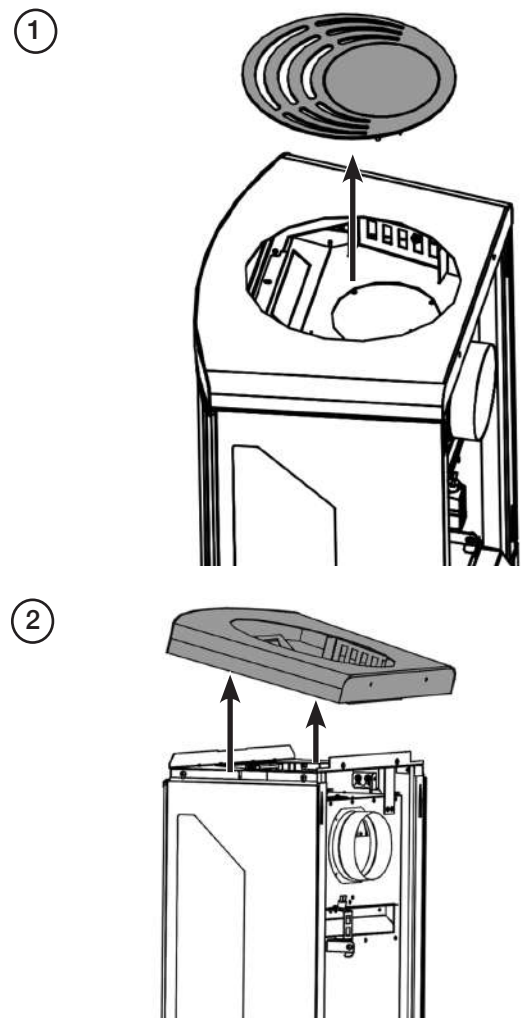

ALL MODELS

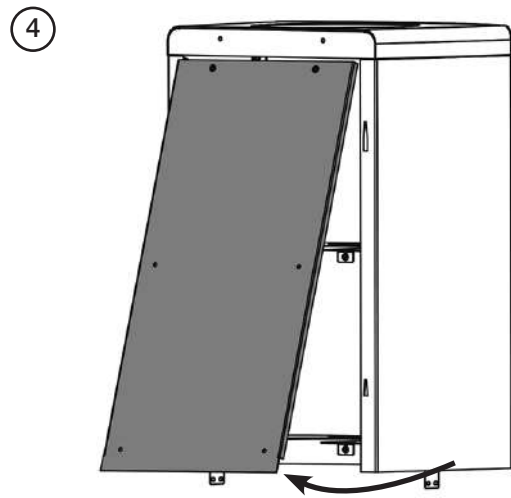
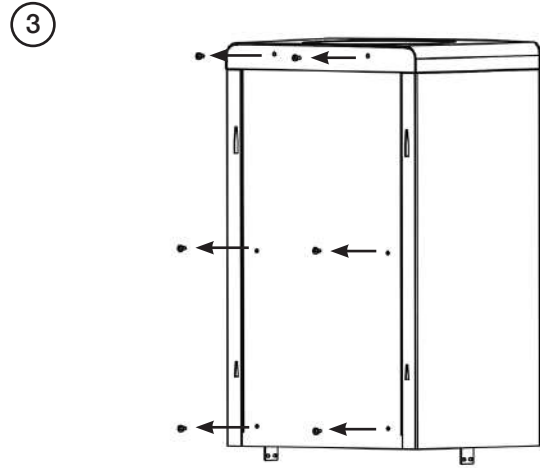
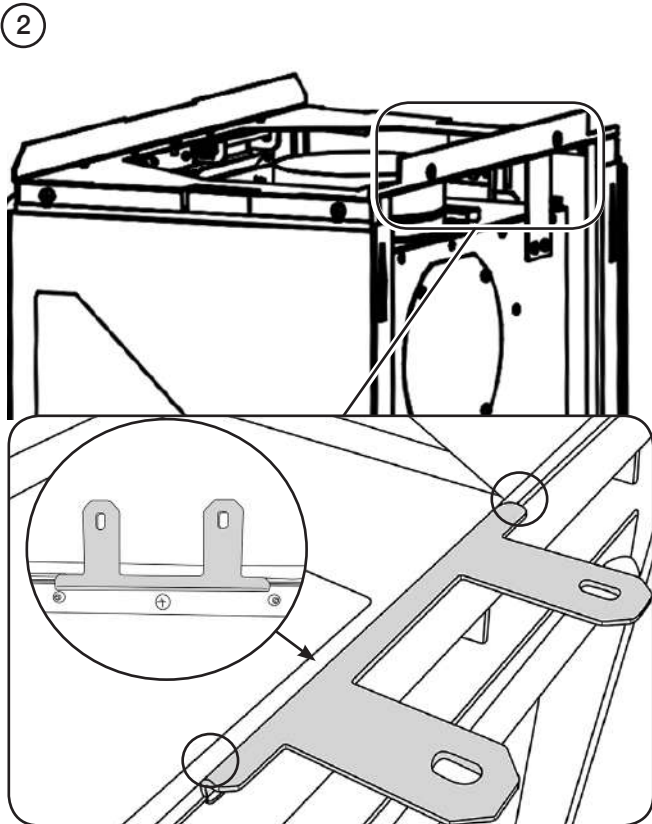
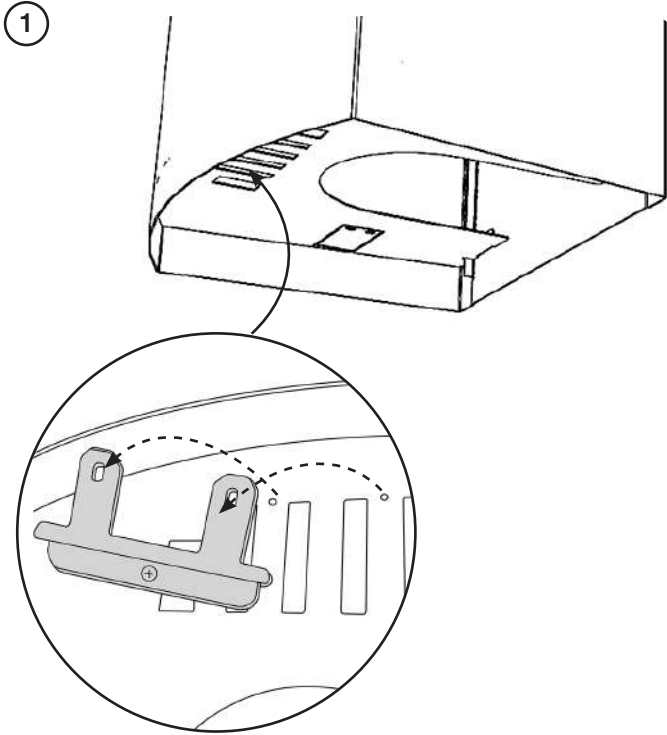

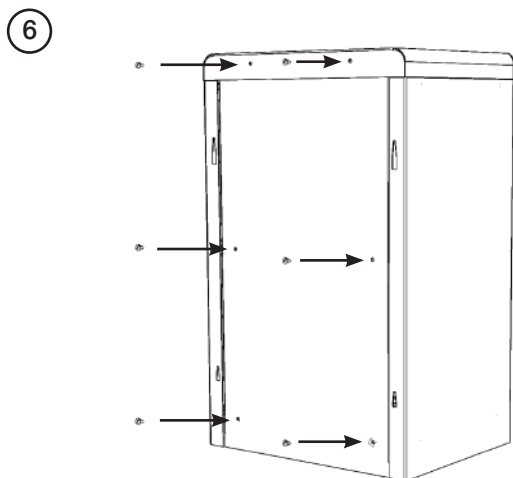
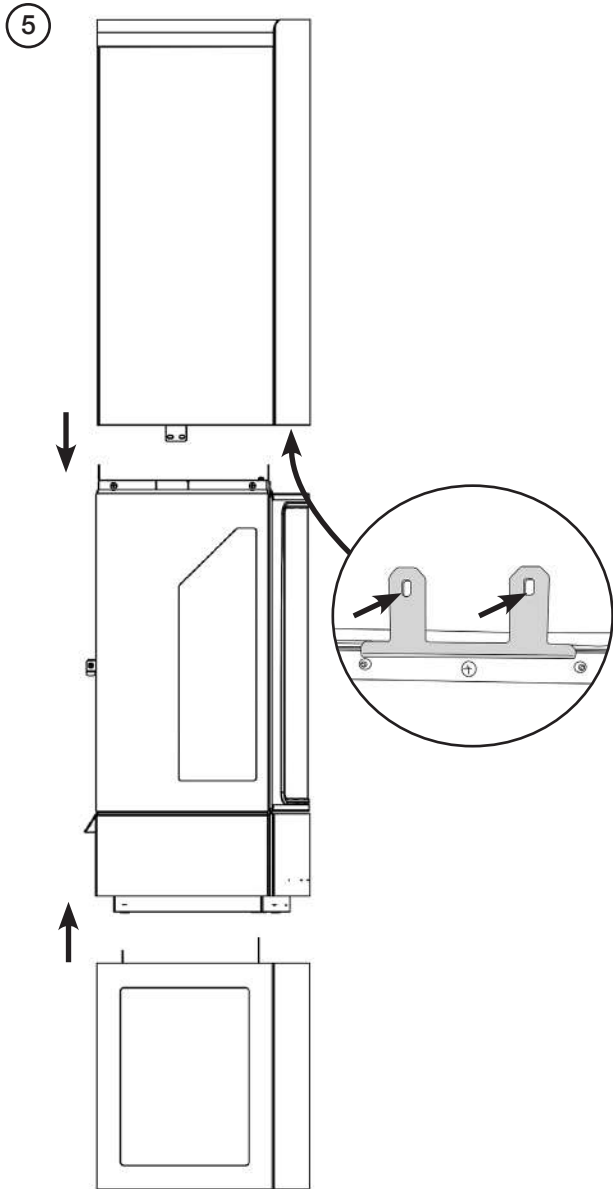

TOP EXIT

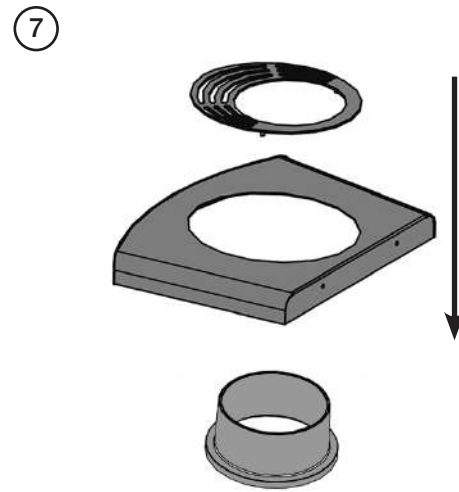

REAR EXIT

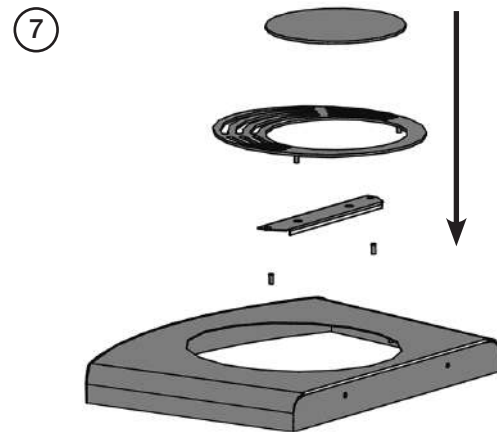

GAS SOUNDNESS PRESSURE CHECK

Purge the supply pipe.

This is essential to expel any debris that may block the gas controls.

Connect the gas to the 8mm elbow on the rear of the appliance.

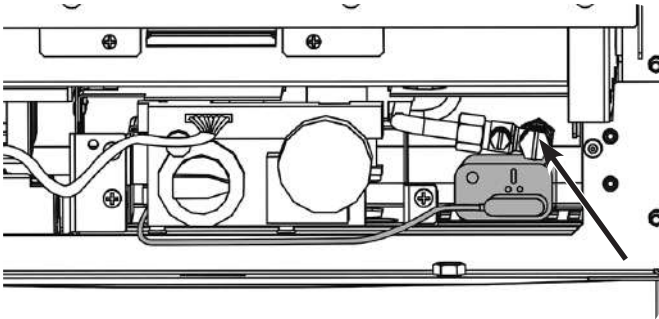

Connect a suitable pressure gauge to the test point located on the inlet fitting and turn the gas supply on. Light the appliance and check all gas joints for possible leaks. Turn the appliance to maximum and check that the supply pressure is as stated on the databadge. Turn the gas off and replace the test point screw, turn the gas on and check the test point for leaks.

REMOVING THE GLASS DOOR



IMPORTANT: THE OUTER PANNELLING OF THE GAZCO LOFT IS MADE FROM CAST IRON. USE CAUTION WHEN INSTALLING, REMOVING AND STORING AS THE COMPONENTS ARE HEAVY AND SHOULD BE HANDLED CAREFULLY.

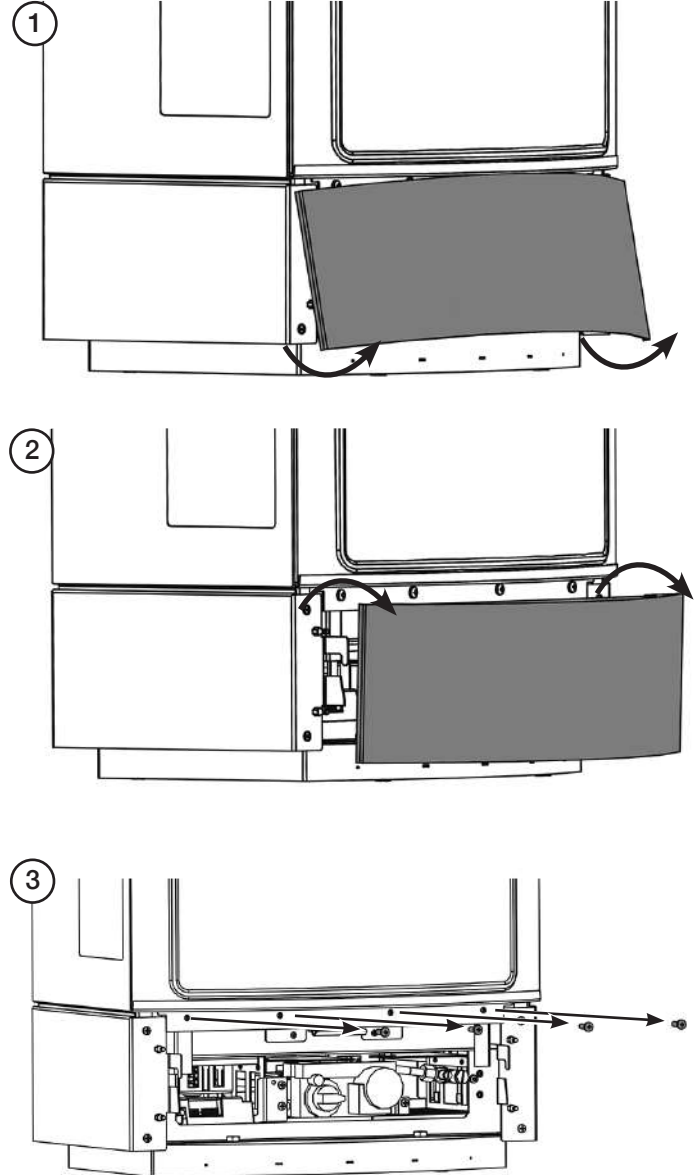

i

NOTE: SUPPORT DOOR WHEN REMOVING.

4

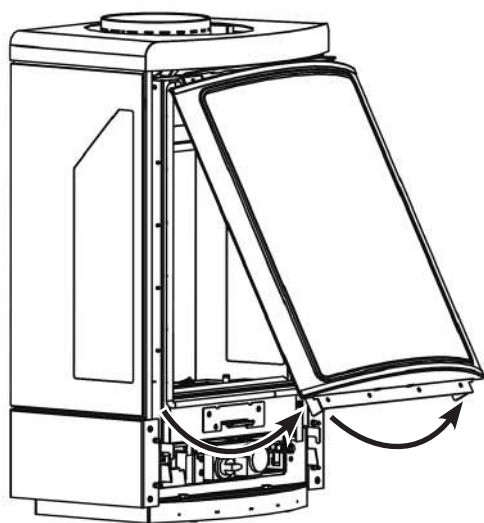

BATTERY INSTALLATION

The appliance batteries are located on a bracket located behind the lower plinth.

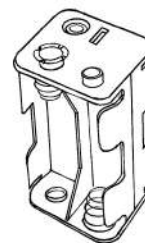
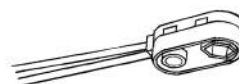
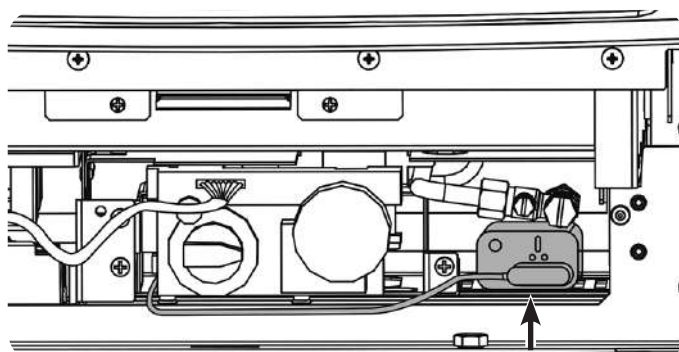

Correctly position the 4 new AA size batteries into the battery holder.

Replace the battery holder.

i

It is essential to use high quality batteries (Duracell or equivalent) when replacing batteries in the handset or control box.



PLEASE ENSURE NO WIRES ARE TRAPPED BEFORE REPLACING THE PLINTH. THE LEAD IS EASILY DAMAGED.

LOG LAYOUT

LOGS MUST BE POSITIONED ACCORDING TO THE FOLLOWING INSTRUCTIONS TO GIVE THE CORRECT FLAME EFFECT.

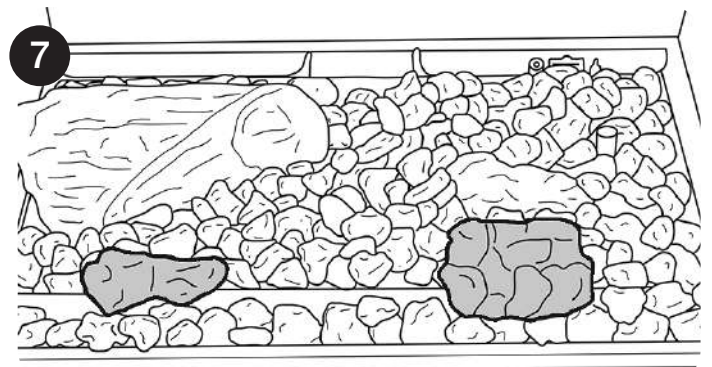
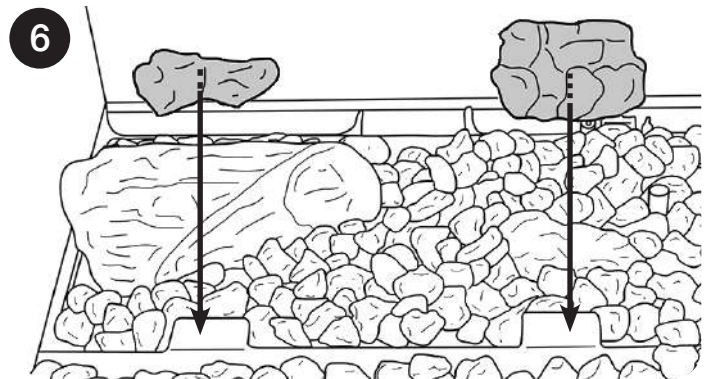
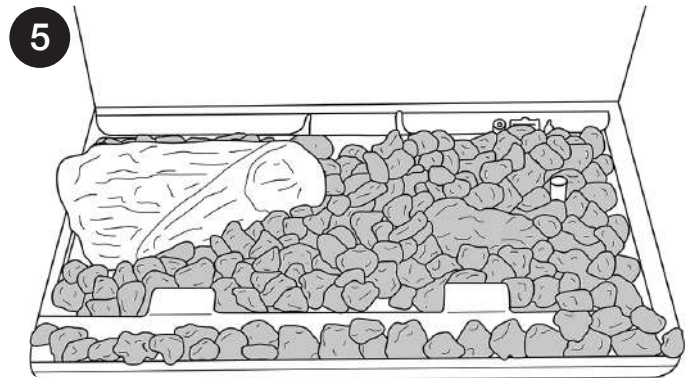
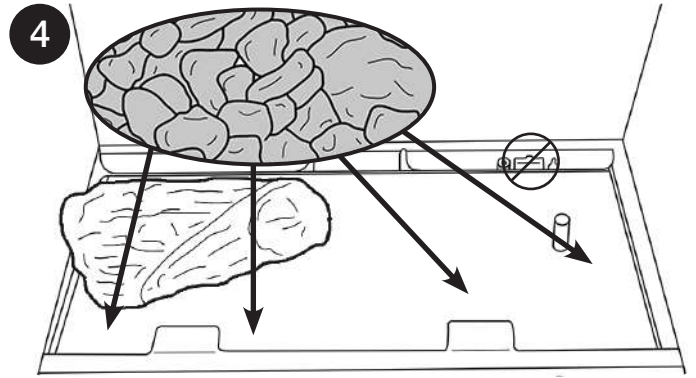
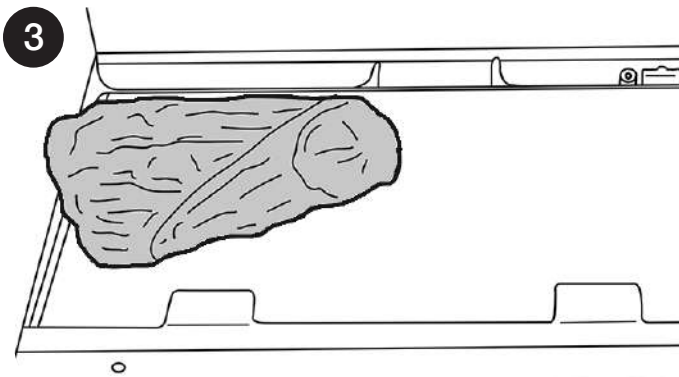
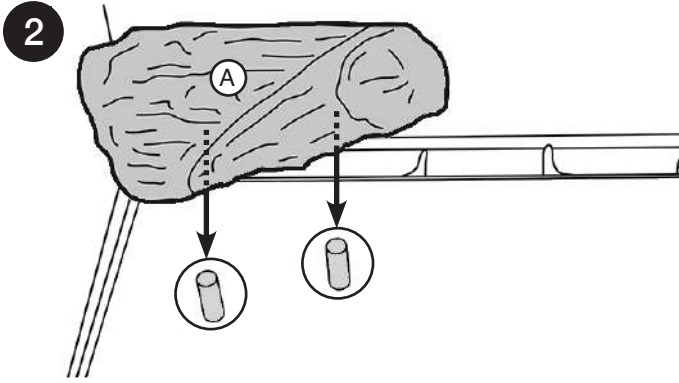
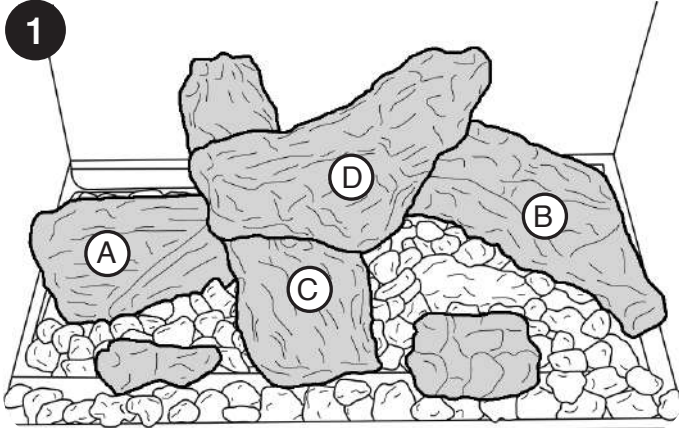

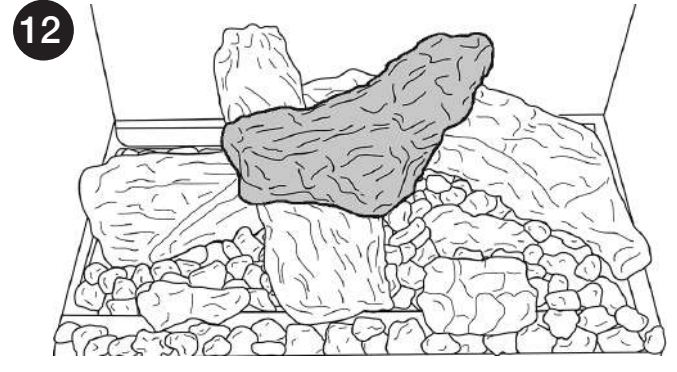
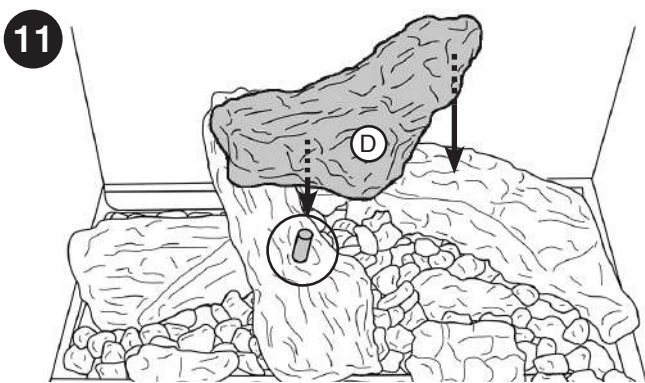
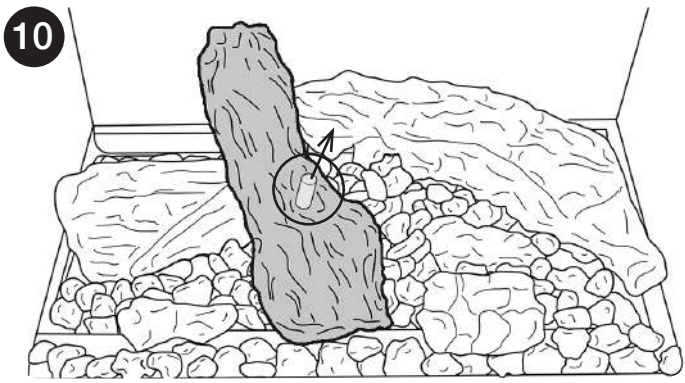
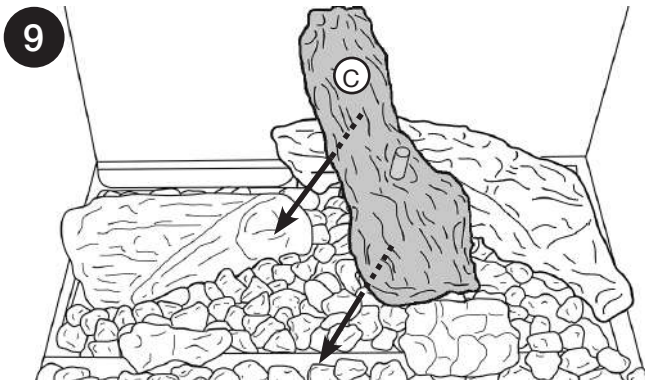
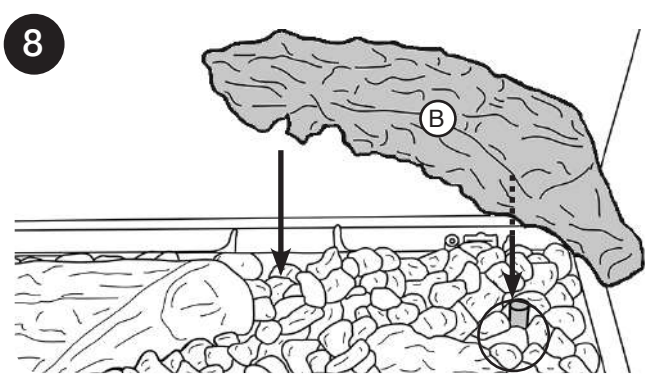

! IT MAY NOT BE NECESSARY TO USE ALL THE EMBAGLOW IN THIS PACK. SPARINGLY SPREAD AN AMOUNT OF THE FIBRES PROVIDED ON THE SECTIONS HIGHLIGHTED IN THE INSTRUCTIONS. Take care not to use more than specified in the instructions.

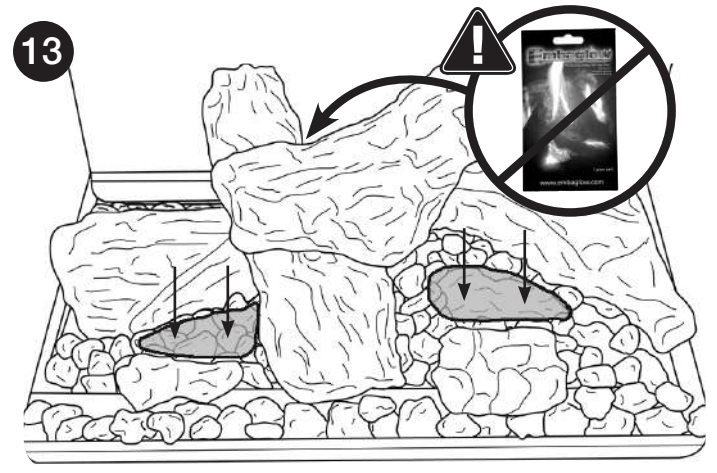

WARNING:
DO NOT PLACE NEAR THE PILOT AREA.
 Do not place Embaglow in the area around the pilot burner - see highlighted example on diagram as this may effect the ignition process and flame picture.

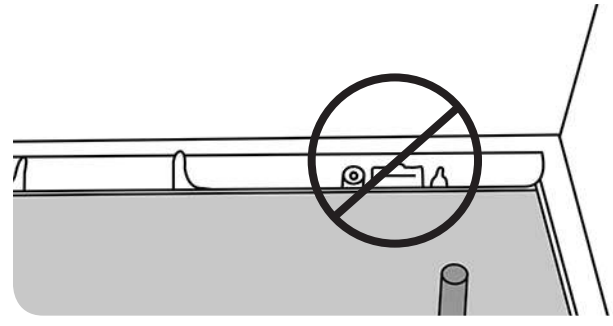

REFITTING THE DOOR

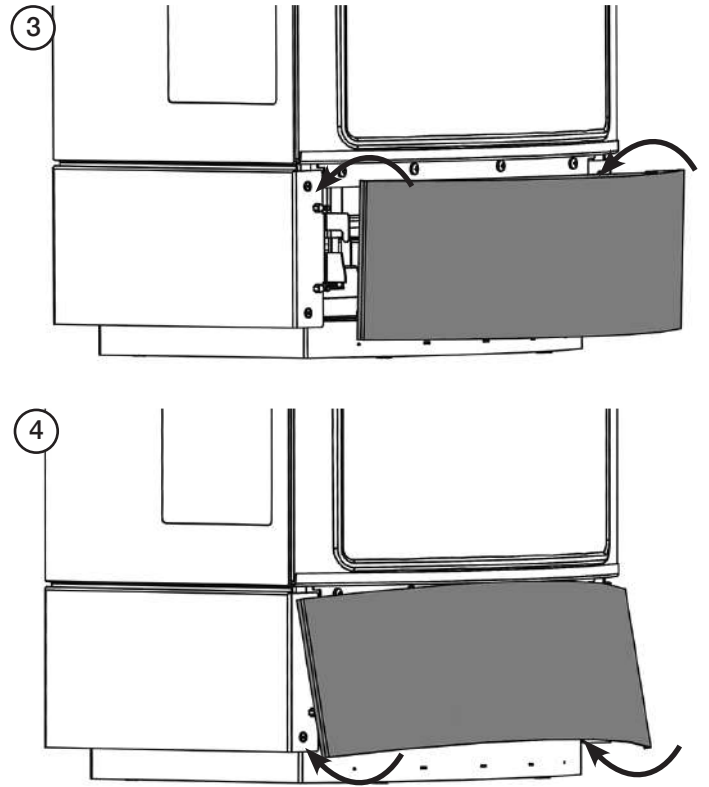
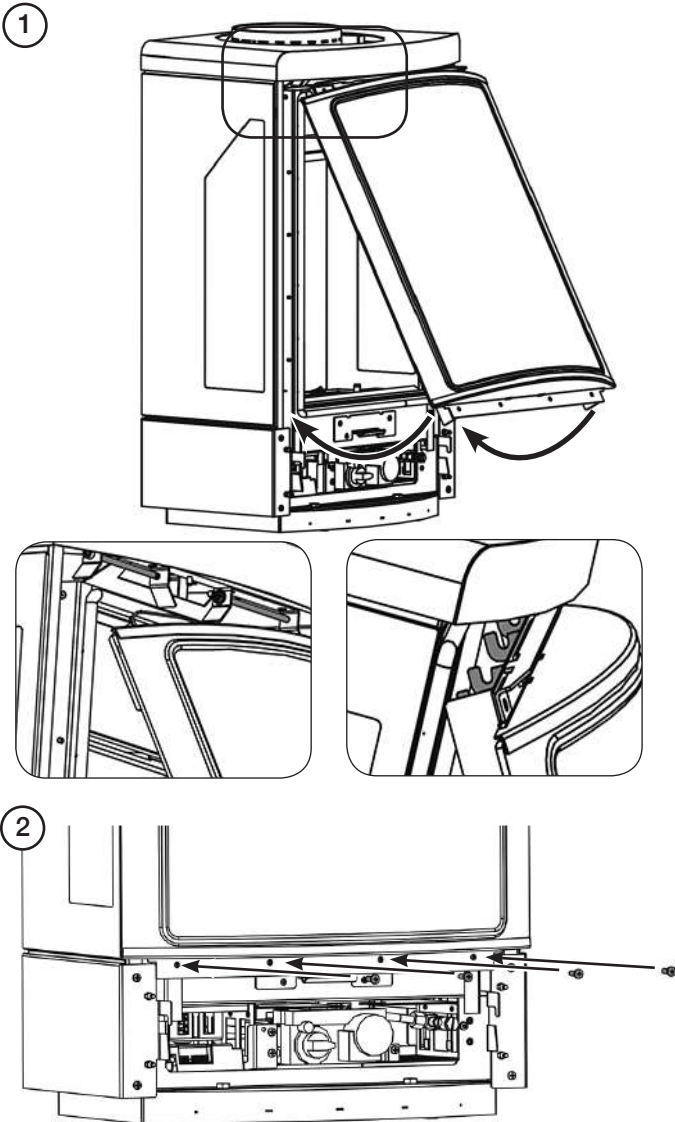

! UNDER NO CIRCUMSTANCES SHOULD THE APPLIANCE BE USED IF ANY OF THE GLASS FRAME RETAINING SCREWS ARE LOOSE OR MISSING.

OPERATING THE APPLIANCE

FOR FULL OPERATING INSTRUCTIONS AND TROUBLESHOOTING SEE USER SECTION.



1 Mode Settings
See Advanced Controls instructions

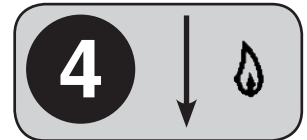
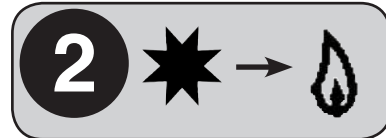

IMPORTANT: YELLOW FLAMES TYPICALLY APPEAR WHEN THE APPLIANCE HAS REACHED NORMAL OPERATING TEMPERATURE. THIS CAN TAKE UP TO 30 MINUTES.



WARNING: IF THE APPLIANCE FAILS TO LIGHT OR BECOMES EXTINGUISHED IN USE, WAIT 3 MINUTES BEFORE ATTEMPTING TO RELIGHT.

COMMISSIONING THE APPLIANCE

Close all doors and windows in the room.

Ignite the appliance and operate on maximum for 10 minutes.

Position a lighted smoke match just inside the draught diverter opening at the rear of the appliance.

Check all smoke is drawn into the opening

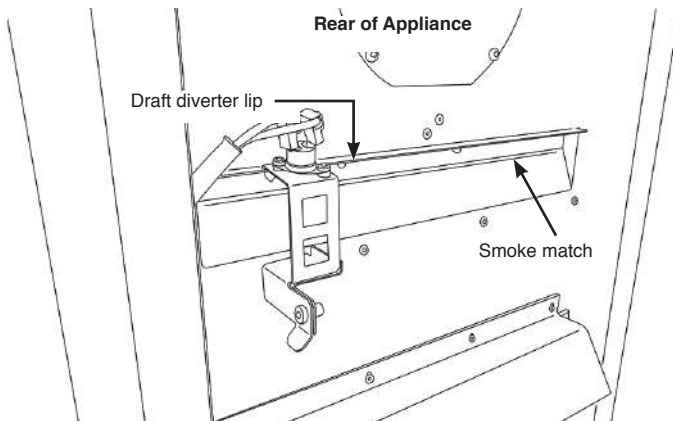

If there is any doubt, run the appliance for a further 10 minutes, and repeat the test.

If there are any extractor fans in adjacent rooms, the test must be repeated with the fans running on maximum and interconnecting doors open.

IF SPILLAGE PERSISTS, DISCONNECT THE APPLIANCE AND SEEK EXPERT ADVICE.

Complete the Commissioning Checklist at the front of this manual covering:

- Thermocouple soundness checks.
This is to include ensuring the thermocouple is secure on the pilot bracket assembly, lead connection and integrity.
- Flue checks
- Gas checks
- Log layout - flame picture

Upon completion of the commissioning and testing of the installation and correct operation of the appliance, the installer must instruct the user how to operate the appliance.

Guide the user through the User Instructions paying particular attention to:

- a) Regular servicing (Section 9 of the User Instructions).
- b) Ventilation (Section 10 of the User Instructions) - point out the ventilation positions where applicable.
- c) Hot surfaces (Section 12 of the User Instructions).

SERVICING INSTRUCTIONS

SERVICING REQUIREMENTS/ FAULT FINDING CHARTS



IMPORTANT – Check the glass panel on this appliance for any signs of damage on the glass panel (scratches, scores, cracks or other surface defects). If damage is observed, the glass panel must be replaced and the appliance must not be used until a replacement is installed.
DO NOT USE the appliance if any damage is observed.
 Isolate the appliance until a replacement has been obtained and installed. Purchase replacement glass panels from Gazco via the retailer from which the appliance was purchased or any other Gazco distributor.

This appliance must be serviced at least once a year by a competent person.

All tests must be carried out in accordance with the current Gas Safe recommendations.

BEFORE TESTING:

- Conduct a gas soundness test for the property ensuring there are no leaks before servicing.
- Check the operation of the appliance before testing.

SPECIAL CHECKS:

- Clean the burner using a vacuum cleaner with a soft brush attachment. Ensure all debris is removed from the burner ports.
- Clean away lint or fluff from the pilot.
- Clean away lint or fluff from under the burner.
- Check the spark gap on the pilot is correct.
- Ensure that the glass frame is secured correctly and that all retaining screws are in place.

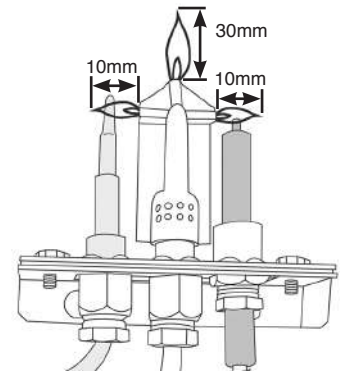

Correct any faults found during the initial test.

Re-commission the appliance in accordance with Commissioning Procedures.

Advise the customer of any remedial work undertaken.

IGNITION FUNCTIONAL CHECK 1

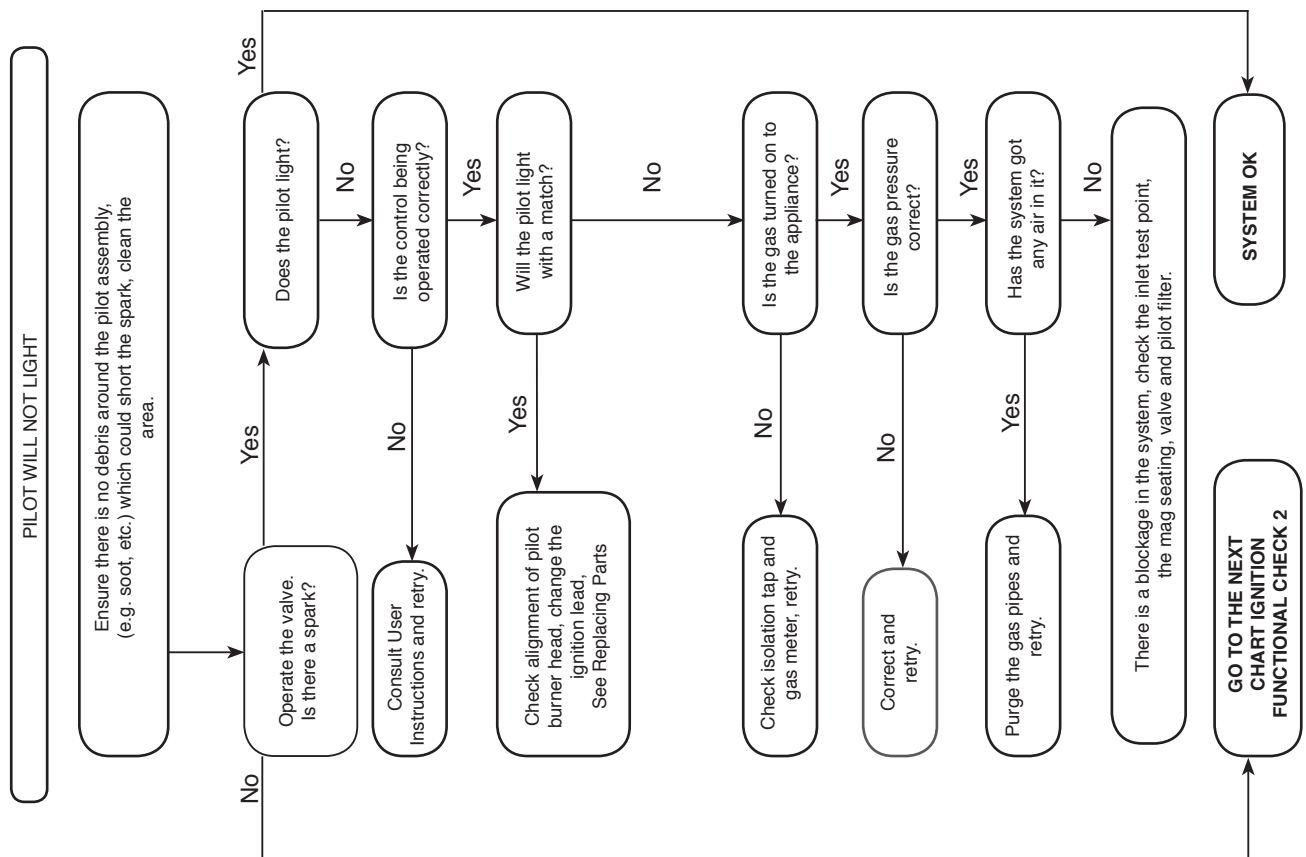

FAULT FINDING CHARTS

FLAME FAILURE FUNCTIONAL CHECK 3

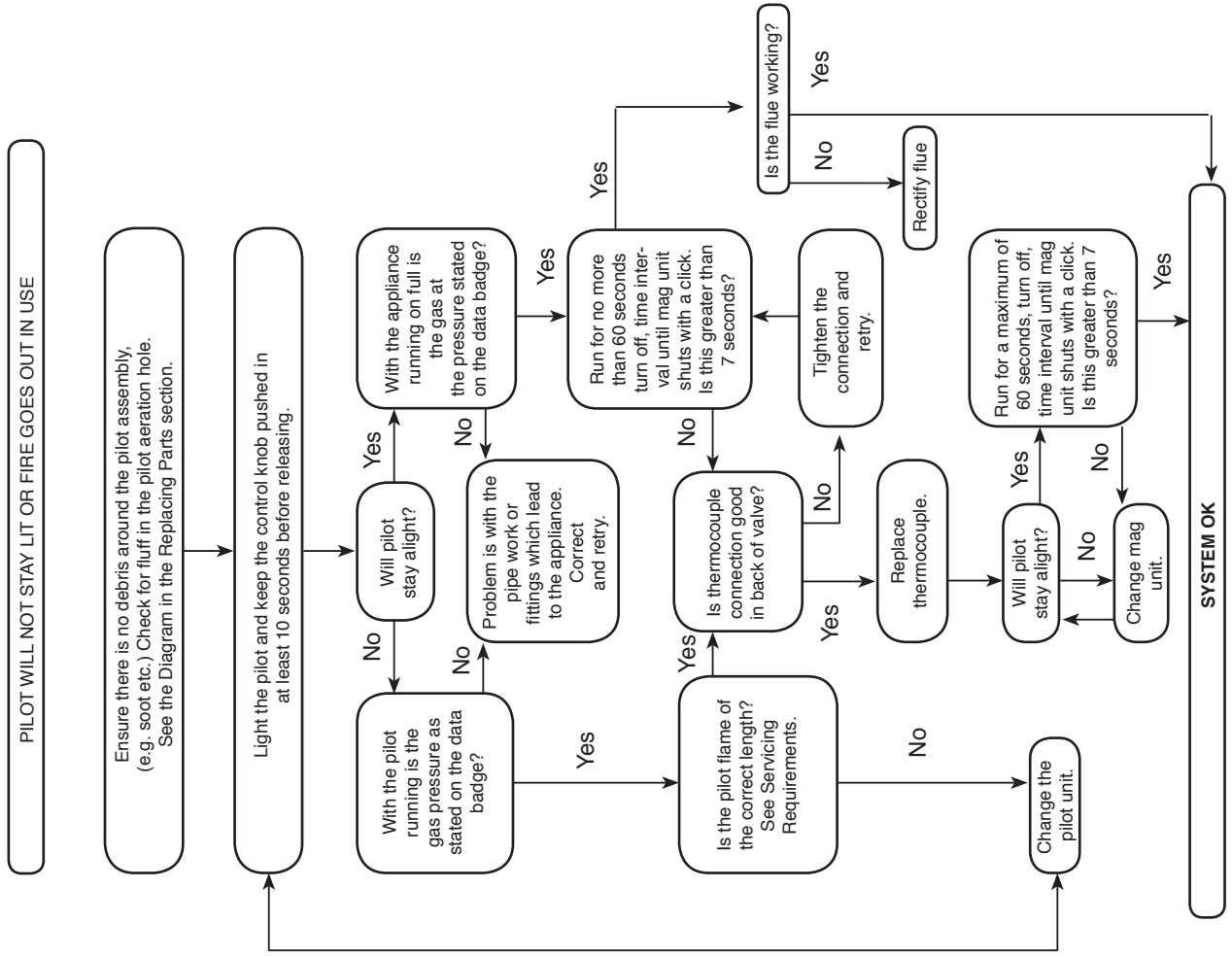

IGNITION FUNCTIONAL CHECK 2

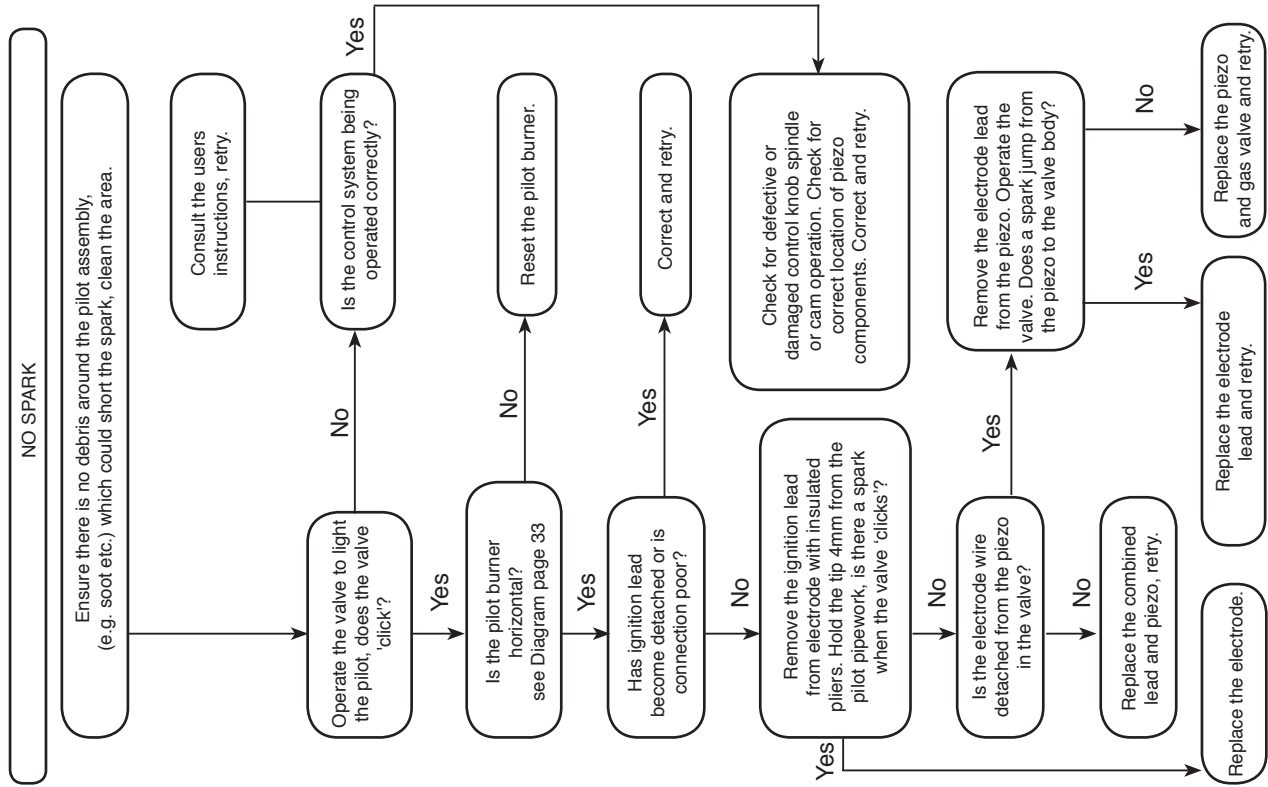

SERVICING

All main components can be replaced without removing the appliance from its installation.

IT IS ESSENTIAL THAT THE GAS SUPPLY TO THE APPLIANCE IS TURNED OFF AT THE ISOLATION DEVICE BEFORE PROCEEDING FURTHER.

Removal of Flue:

If, for any reason, the flue has to be removed from the appliance, the seal must be replaced in the inner spigot.

SERVICING AND SUPPORT



Servicing and Support

To keep your appliance looking and performing at its best, it must be serviced annually. This service must be undertaken by a suitably qualified individual and your retailer can organise this for you. Alternatively, Gazco offer a manufacturers premium service with our friendly team of qualified engineers which can be booked at www.gazco.com/support

REMOVING THE GLASS DOOR



IMPORTANT: THE OUTER PANNELLING OF THE GAZCO LOFT IS MADE FROM CAST IRON. USE CAUTION WHEN INSTALLING, REMOVING AND STORING AS THE COMPONENTS ARE HEAVY AND SHOULD BE HANDLED CAREFULLY.

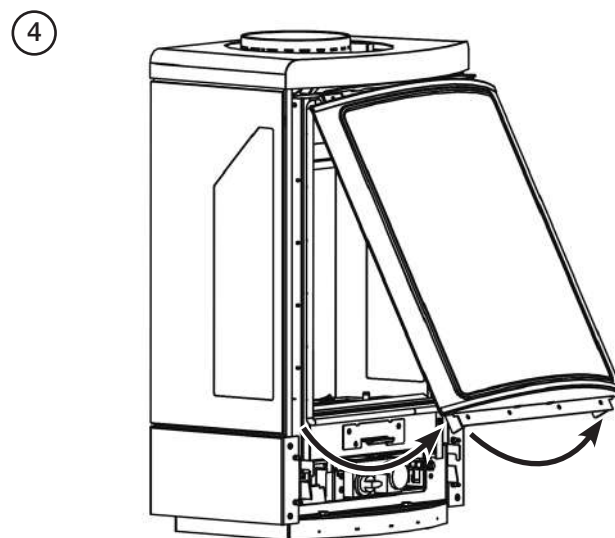
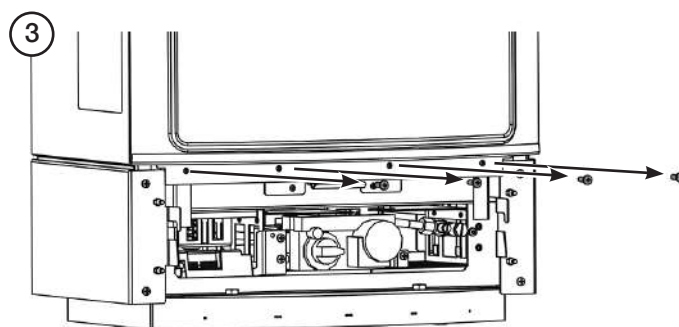
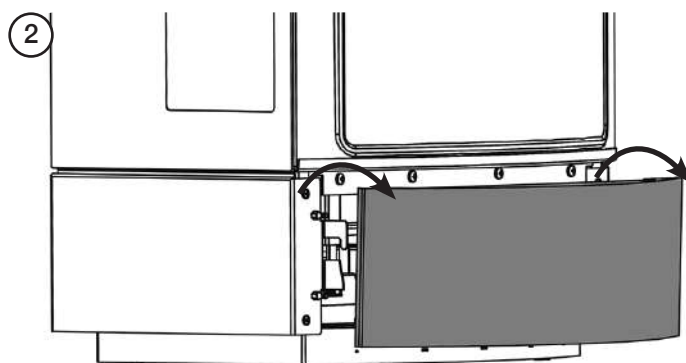
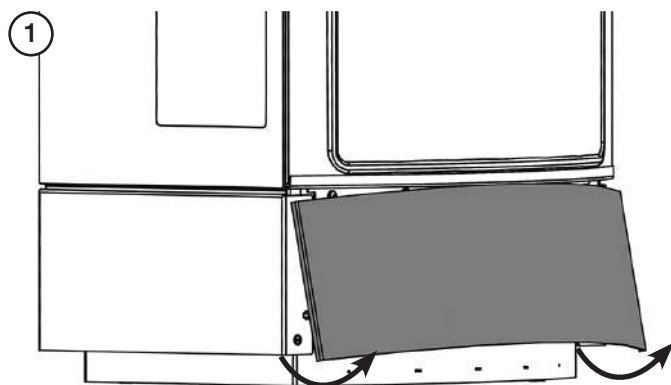

REFITTING THE DOOR

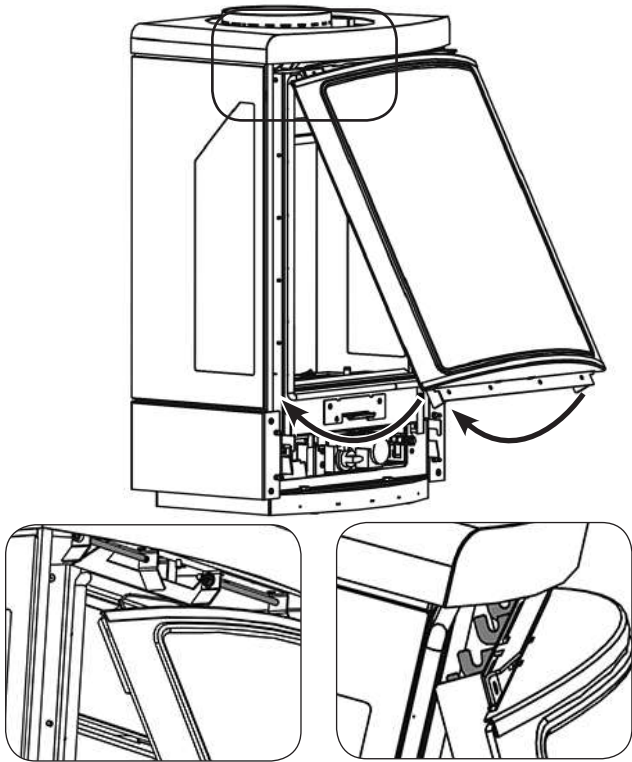

UNDER NO CIRCUMSTANCES SHOULD THE APPLIANCE BE USED IF ANY OF THE GLASS FRAME RETAINING SCREWS ARE LOOSE OR MISSING.

BAFFLE & LINERS

To access the burner tray and interior workings of the appliance it may be necessary to remove the baffle and the liners.

BAFFLE

The baffle consists of two parts:

- Main Baffle.
- Rear Baffle.

①

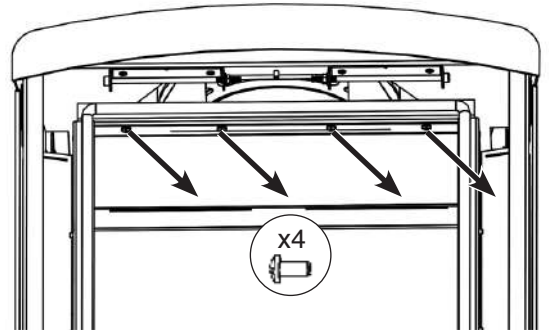

②

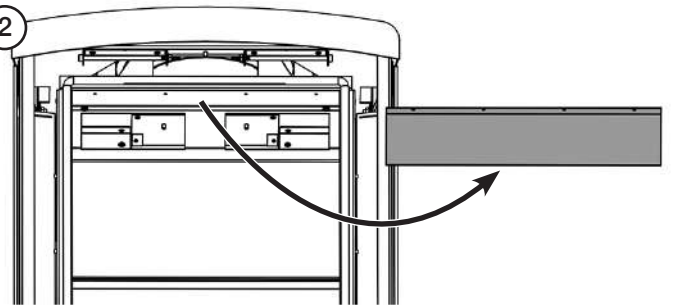

③

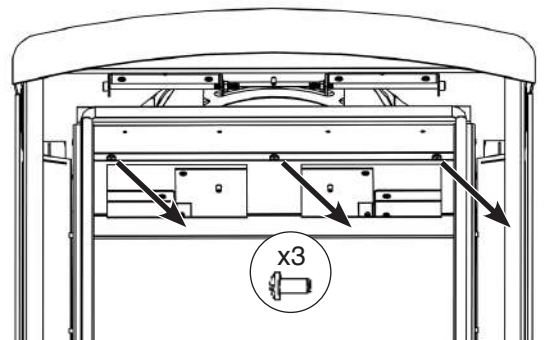

④

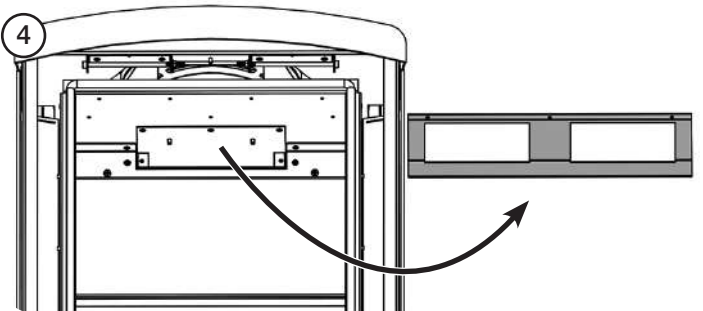

REAR PANEL & TRIMS

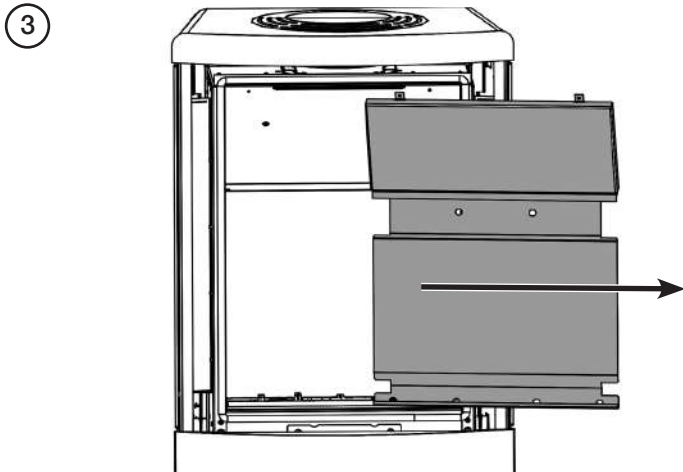
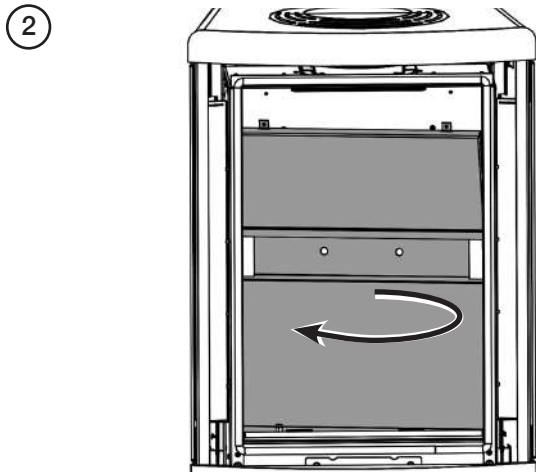
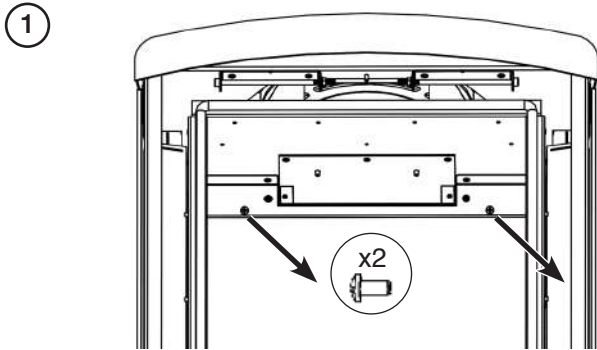

i NOTE: The Side Trims only need to be removed if damaged or the side glass needs replacing.

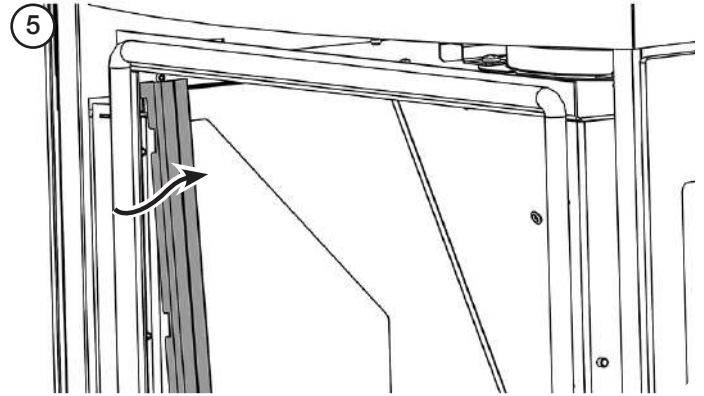
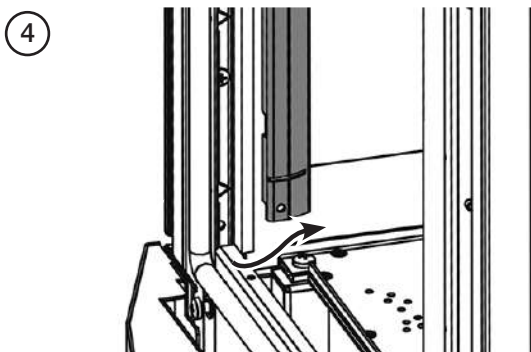

MAIN BURNER

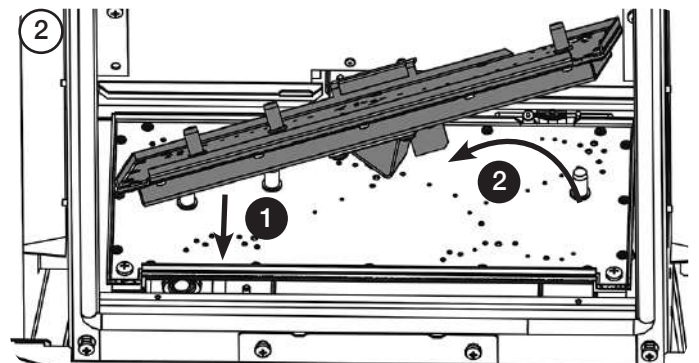
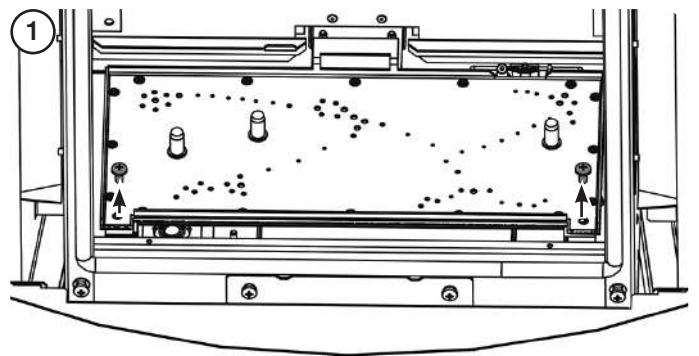

! IMPORTANT: ENSURE THE BURNER ENGAGES WITH THE INJECTOR AT THE BASE OF THE FIREBOX.

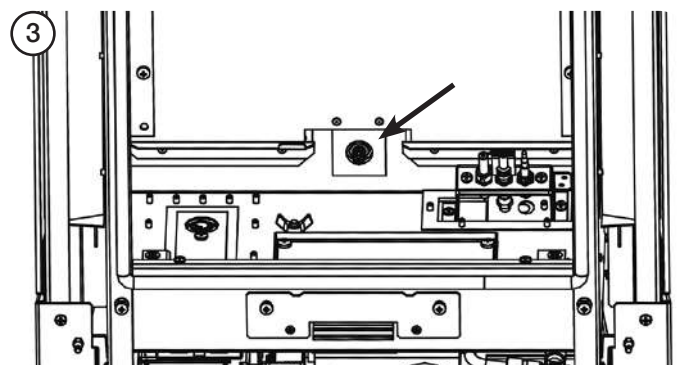

CONTROL ASSEMBLY & SERVICE HATCH

i It is not necessary to remove the complete control assembly to service or replace parts of this appliance. The following sections will detail how to individually remove and replace each element.

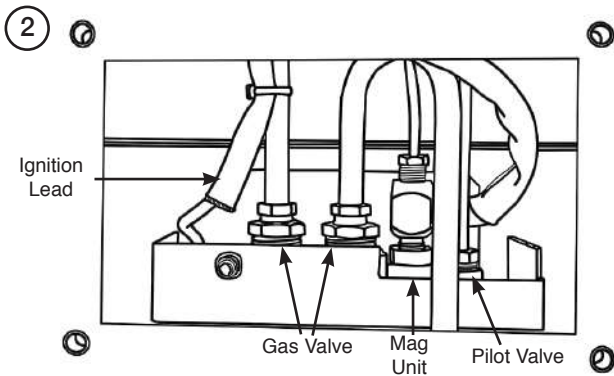
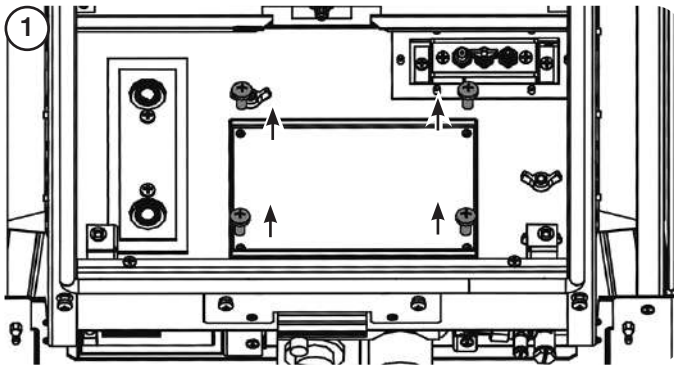

i Reposition the service hatch and tighten the 4 screws.

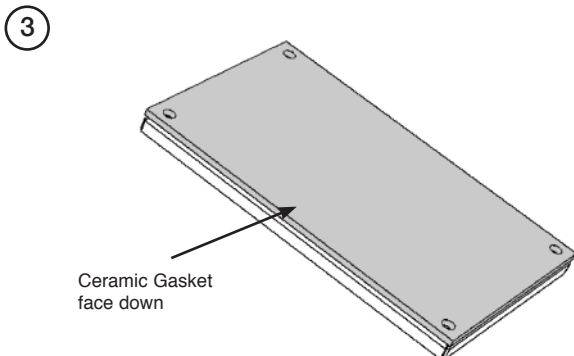

PILOT UNIT

! **IMPORTANT: UNDER THE TERMS OF THE EXTENDED WARRANTY IT WILL BE COMPULSORY TO CHANGE THE COMPLETE PILOT UNIT ON THIS APPLIANCE IN YEARS 2 AND 4.**

The pilot assembly consists of 4 components which can be individually changed:

- Pilot burner bracket.
- Electrode.
- Pilot injector.
- Thermocouple.

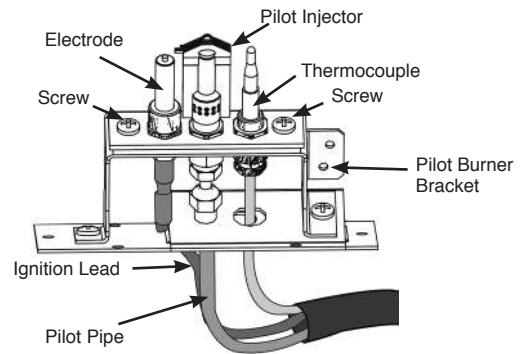

NOTE: Ensure the sealant surrounding the Electrode and Thermocouple leads is replaced if disturbed or removed whilst gaining access to these components.

Turn the gas supply off at the isolation device, remove the door and place to one side, carefully remove the ceramic fuel bed components.

PILOT BURNER BRACKET

i First remove the electrode, pilot pipe and thermocouple as described in the following sections.

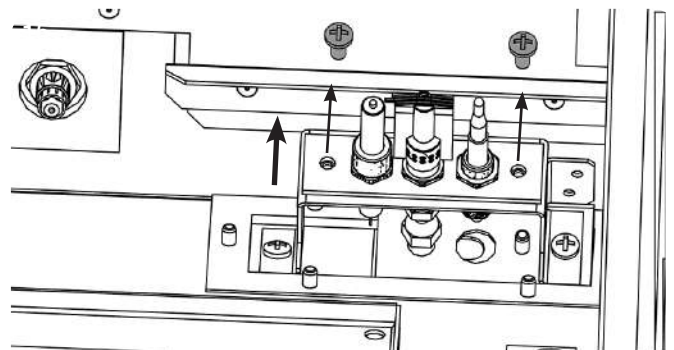

ELECTRODE

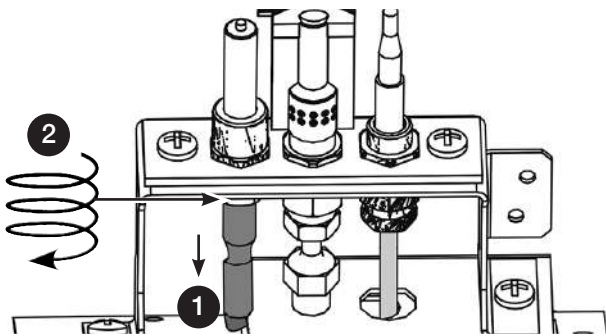

PILOT INJECTOR

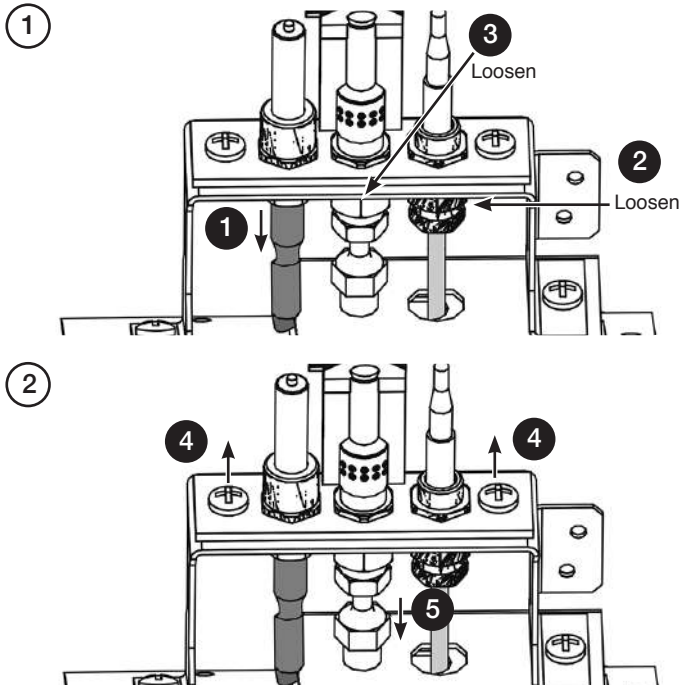

Remove the pipe and the injector drops out from the burner when Pilot Assembly is lifted.

THERMOCOUPLE

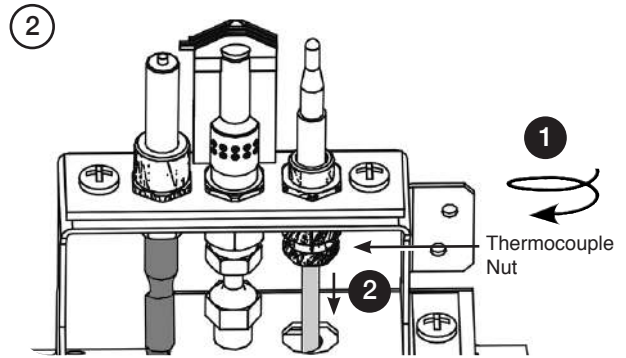
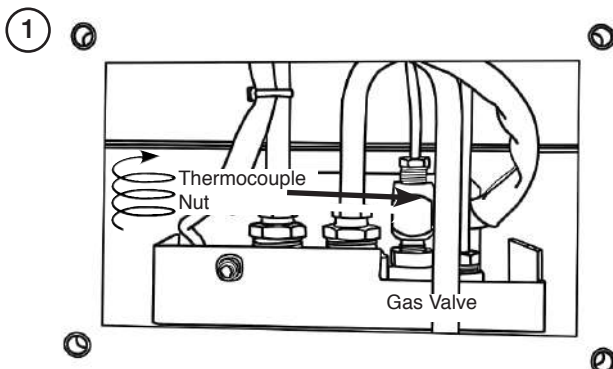

NEW THERMOCOUPLE:

Bend the new component to the same shape as the thermocouple just removed.

Push thermocouple fully into the hole in the pilot bracket. There is a stop on the thermocouple to set the height.

Lock the retaining nut just enough to grip the thermocouple.

Connect the thermocouple to the valve **taking care not to over-tighten.**

IGNITION LEAD

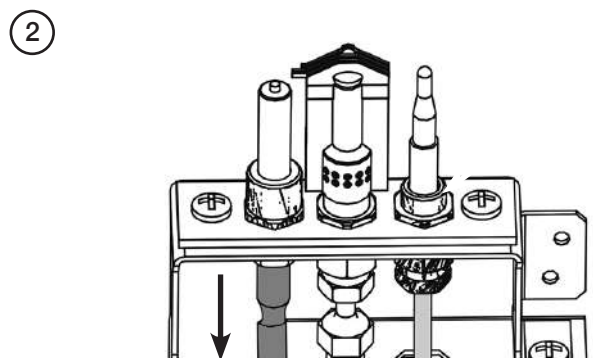
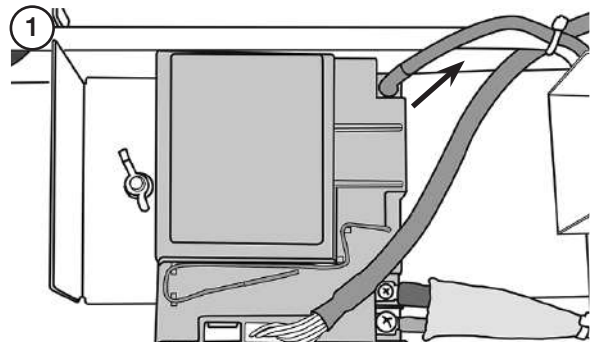

IGNITION LEAD:

Note the direction of the lead. The new lead must follow exactly the same route. Replace cable ties where necessary.



NOTE: THE IGNITION LEAD MUST NOT PASS IN FRONT OF THE CONTROL BOX AS THIS CAN DAMAGE THE SENSITIVE ELECTRONICS.

GAS VALVE

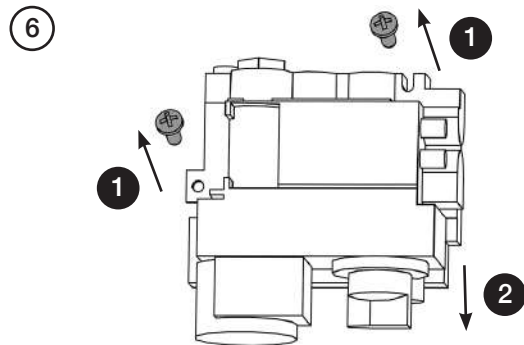
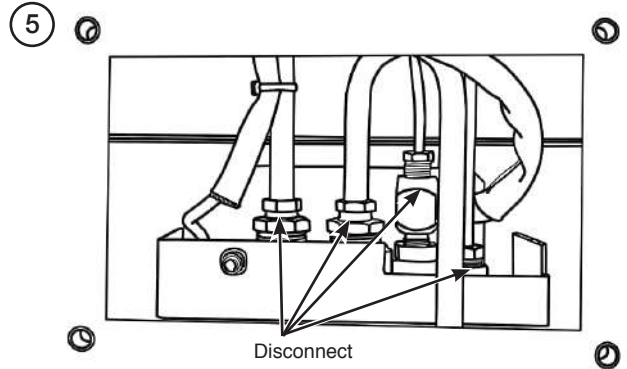
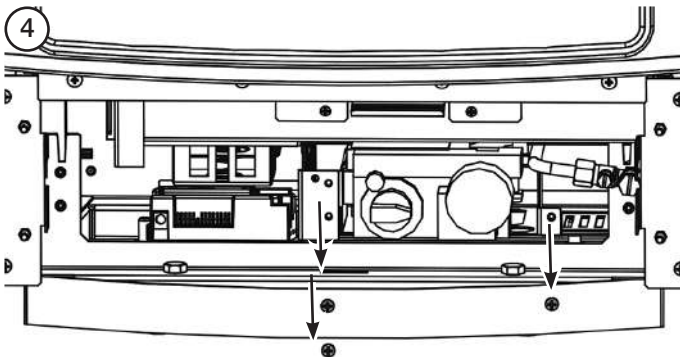
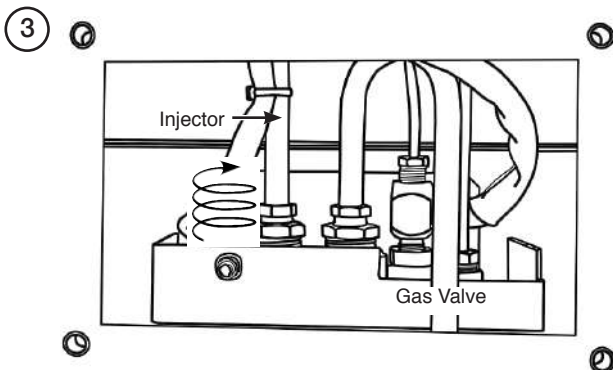
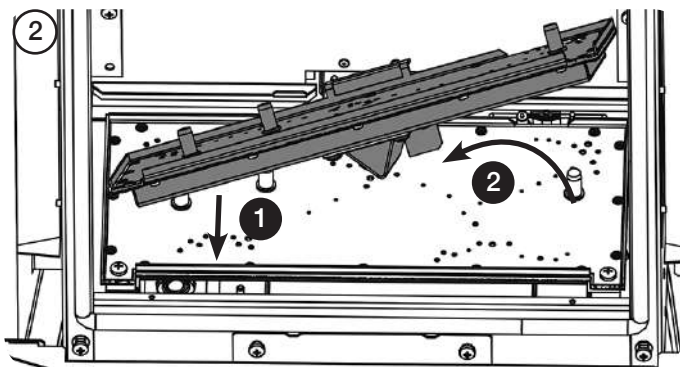
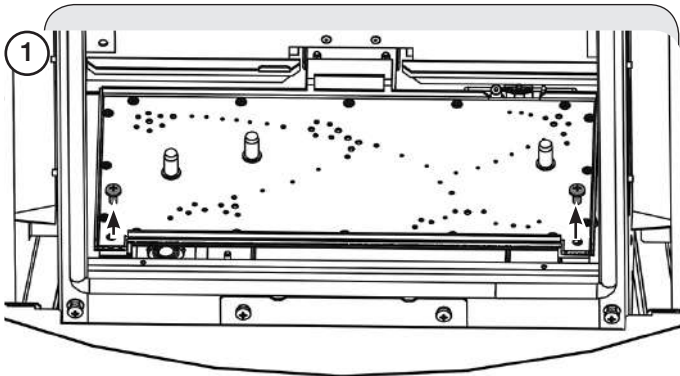

Replace in reverse order.

Check all joints for gas leaks and check operation of the thermocouple and ignition lead.

MAGNETIC SAFETY VALVE



IMPORTANT: TURN OFF THE GAS SUPPLY AT THE ISOLATION DEVICE.

Remove the gas valve.

Undo the magnetic valve-retaining nut from the back of the control valve.

Gently tap out the magnetic valve and replace with a new unit.

Replace the retaining nut and tighten.

Reassemble the interrupter block and leads and secure the thermocouple connection in the rear of the gas control. (Do not overtighten).

Turn the gas supply on and check the entire pipework and valve joints for any leaks.

CONTROL BOX

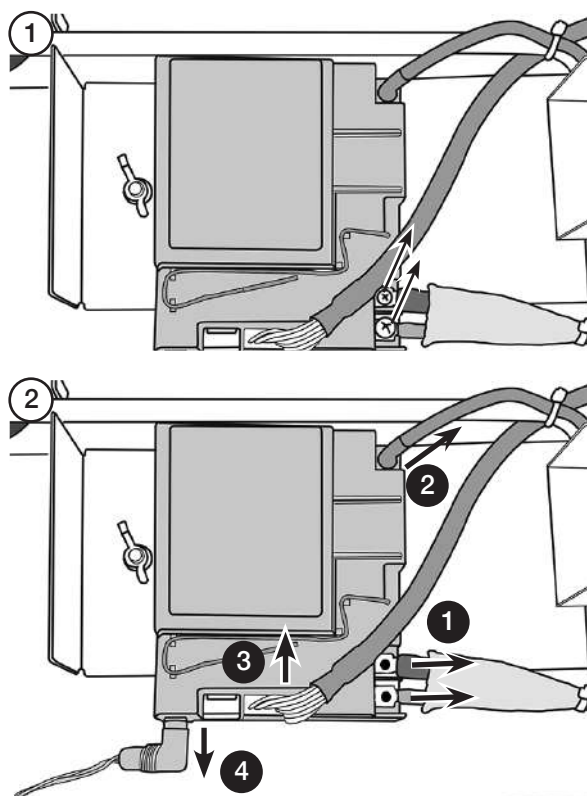

The control box can now be replaced.

When replacing the sealing plate on the rear of the control cover use a suitable silicone sealant.



After replacing the control box you may need to reprogram the handset.

- Press and hold the reset button on the control box until you hear two signals. After the second longer signal:
- Release the reset button and within 20 seconds:
- Press the DOWN button on the handset until you hear two additional short signals confirming the new code is set.

If there is a single long signal the code learning sequence has failed or the wiring is incorrect.

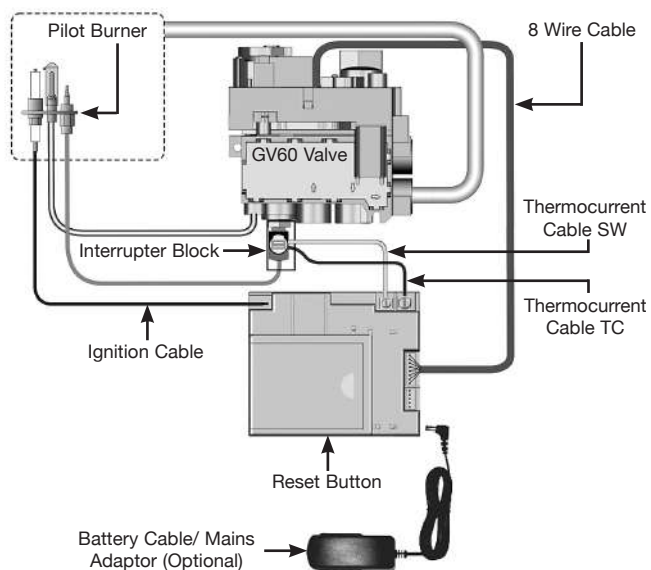

MAIN INJECTOR



IMPORTANT: TURN OFF THE GAS SUPPLY AT THE ISOLATION DEVICE.

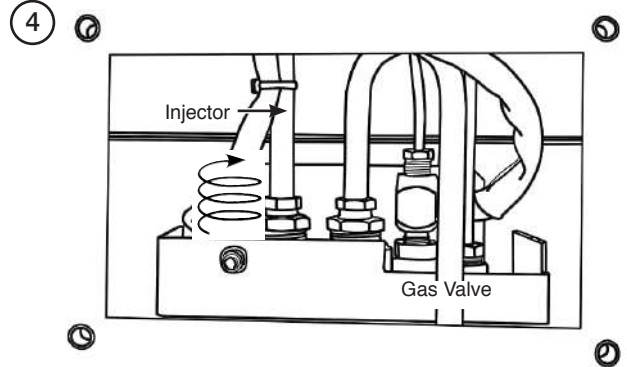
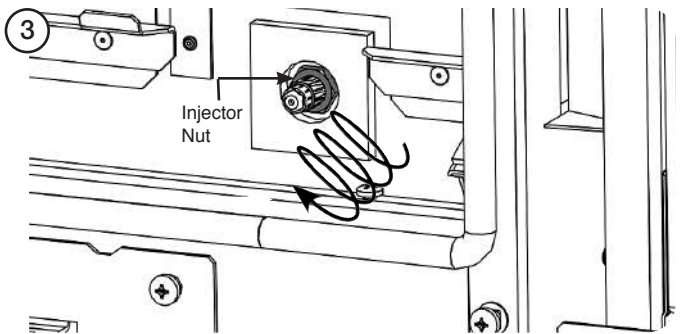
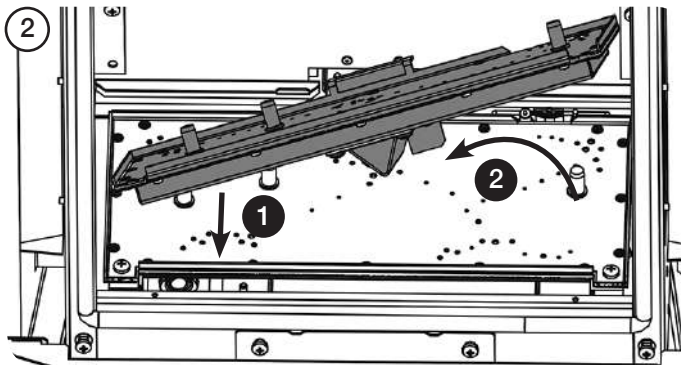
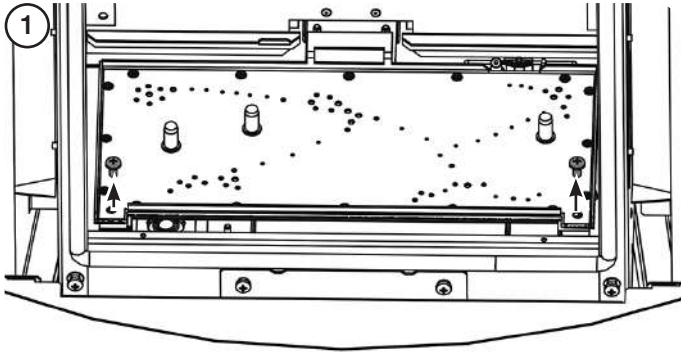

Extract the injector with the feed pipe from beneath the appliance.

Holding the injector with a spanner:

- Undo the feed pipe. **Note the orientation of the Injector.**
- Re-assemble in reverse order.

Turn on the gas supply and check for leaks.

GLASS SIDE PANELS



IMPORTANT: THE OUTER PANNELLING OF THE GAZCO LOFT IS MADE FROM CAST IRON. USE CAUTION WHEN INSTALLING, REMOVING AND STORING AS THE COMPONENTS ARE HEAVY AND SHOULD BE HANDLED CAREFULLY.

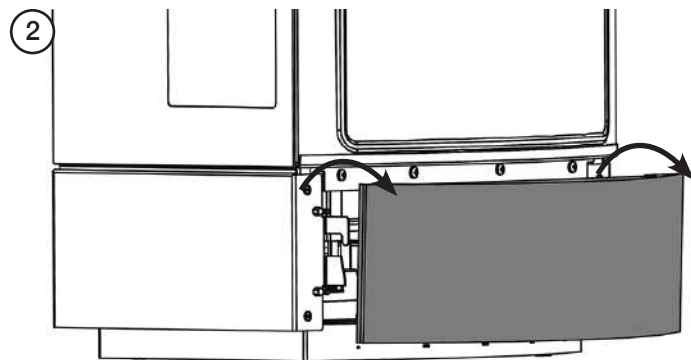
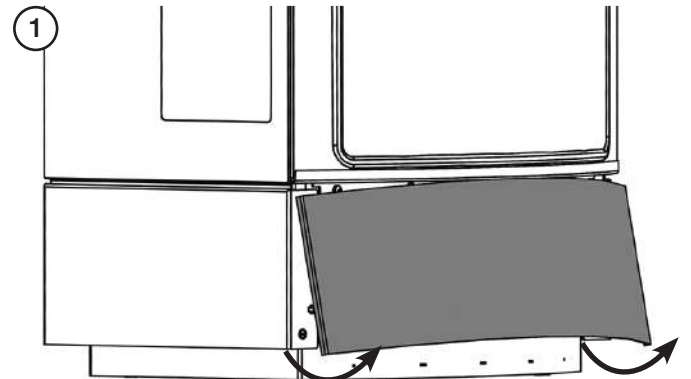

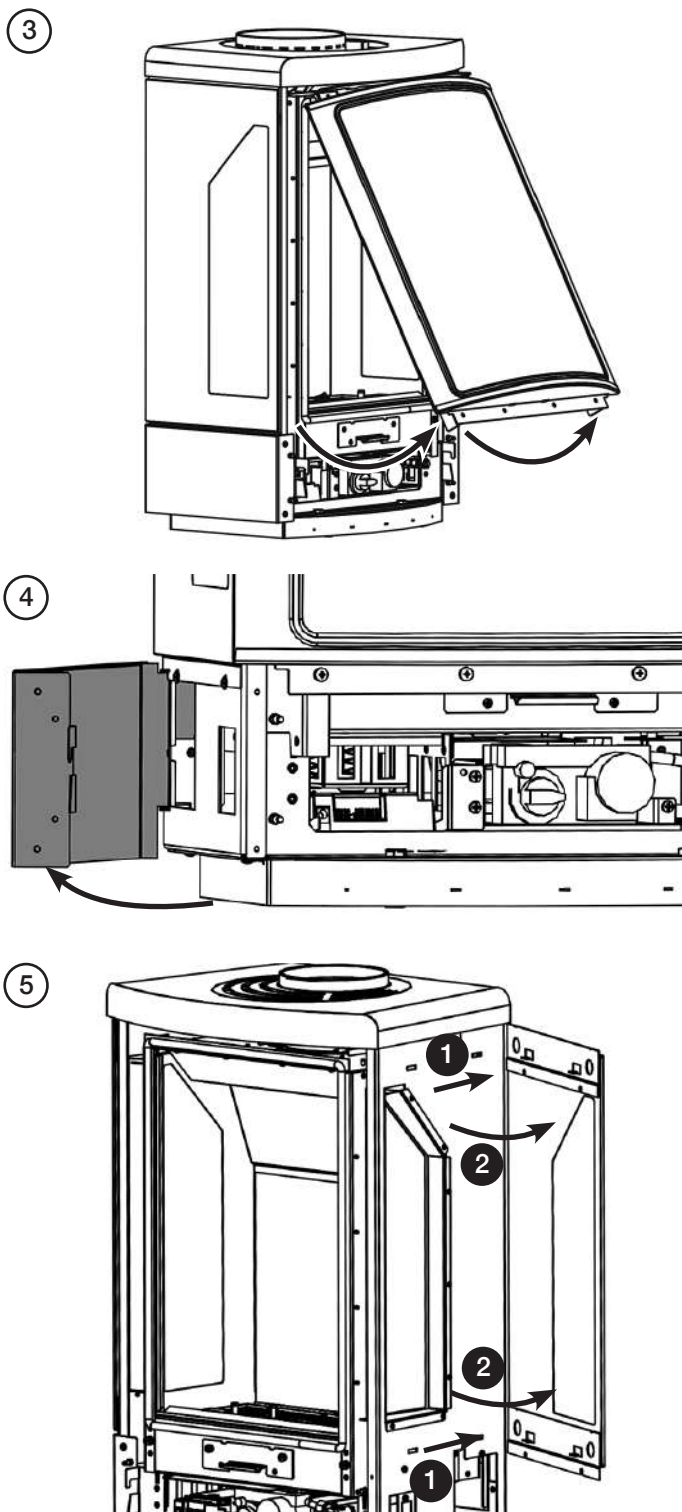

Replace the glass and gasket, ensuring that the printed side is facing outwards.

PRIMARY AERATION PLATE

i NOTE: Not all models have aeration plates. Please refer to the Technical Specification.

! IMPORTANT: TURN OFF THE GAS SUPPLY AT THE ISOLATION DEVICE.

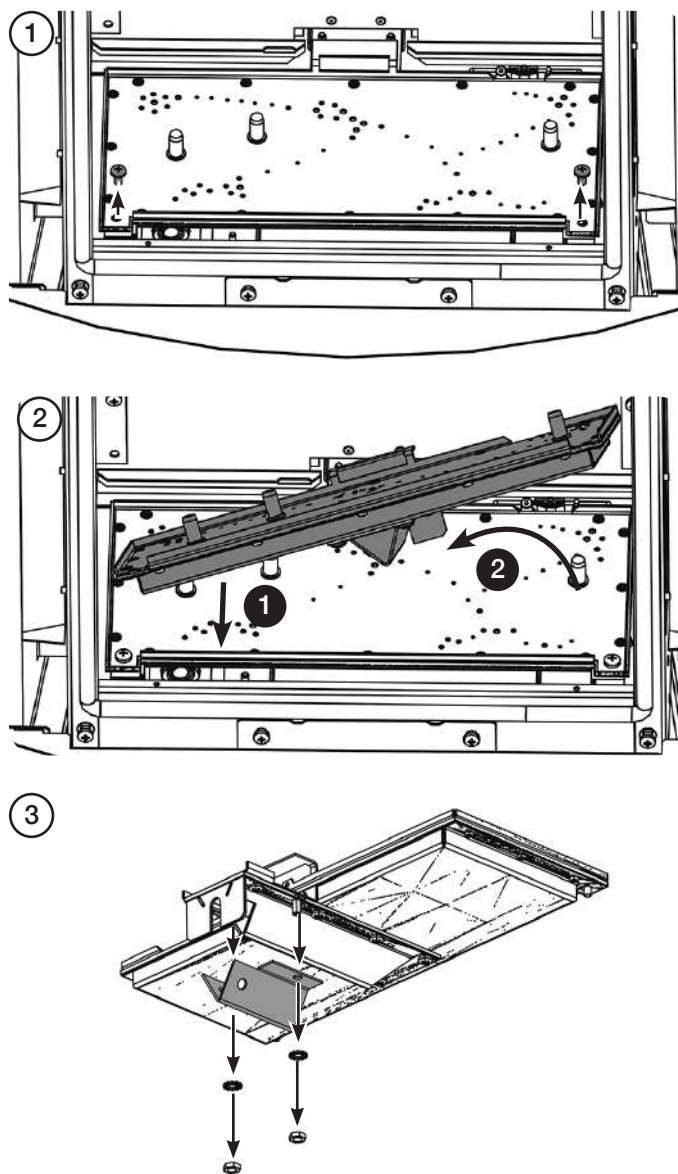

Replace with the correct size plate and secure the 2 nuts. Ensure that the lower edge of the plate is located over the venturi flange.

CHANGING BETWEEN GAS TYPES

A kit of parts is available for this - Contact your Gazco retailer for further information.

It will be necessary to replace the following components:

- Burner
- Injector
- Pilot Injector
- Gas Valve

Always quote the Model number and Serial number when ordering any spare parts.

FLUE SURE SYSTEM

If the appliance has been installed in a restrictive location, it may be necessary to remove the appliance.

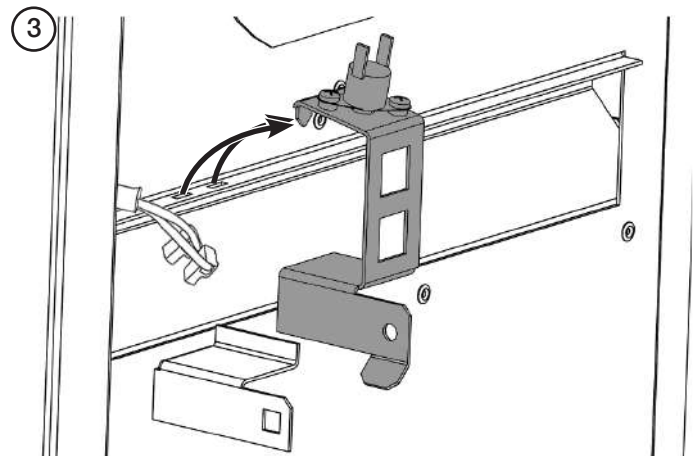
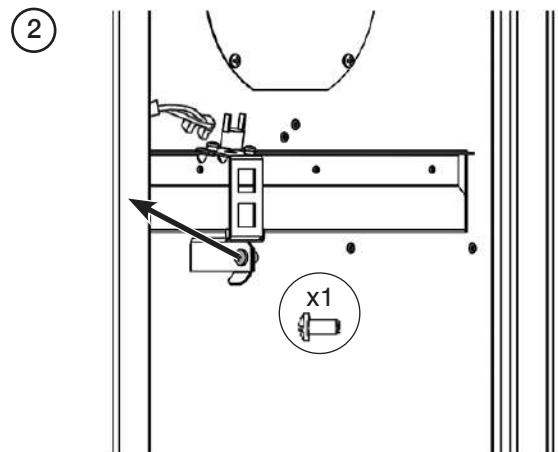
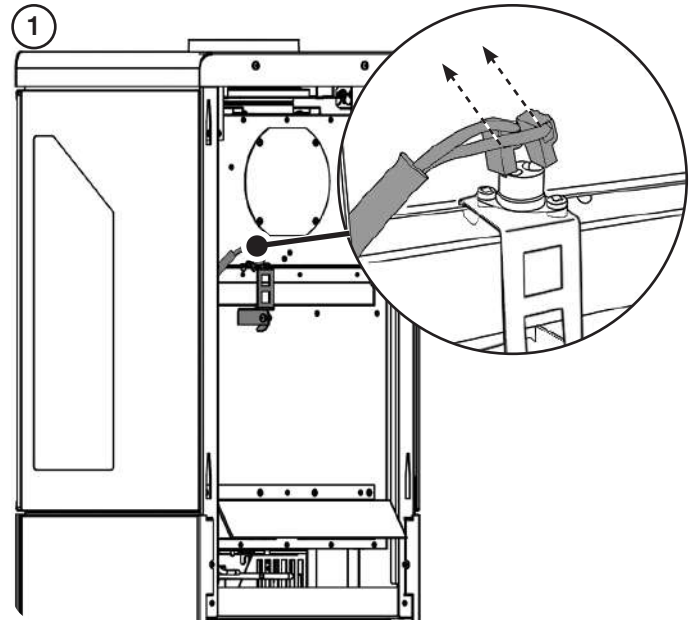

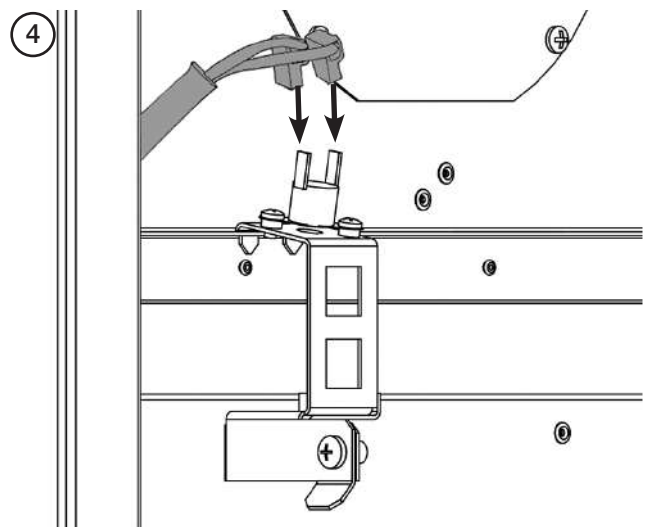
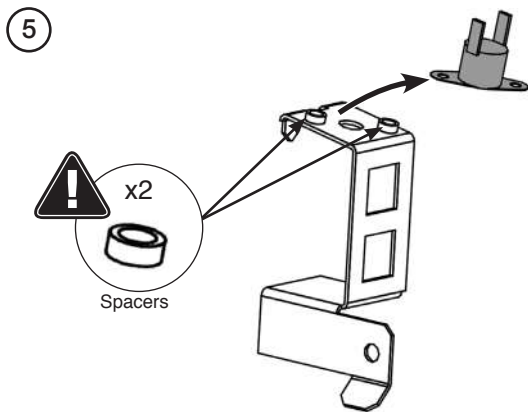
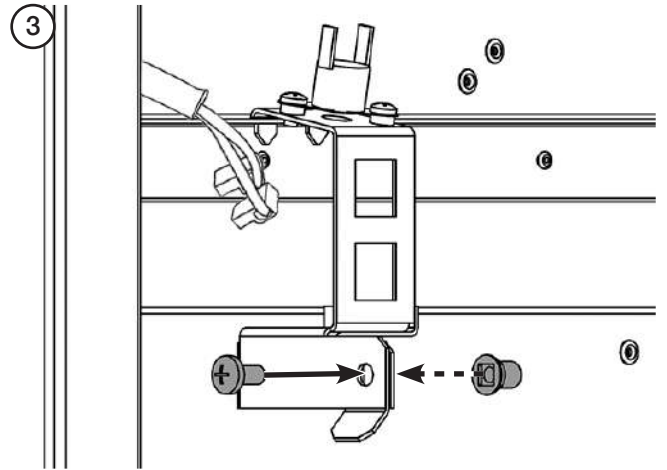
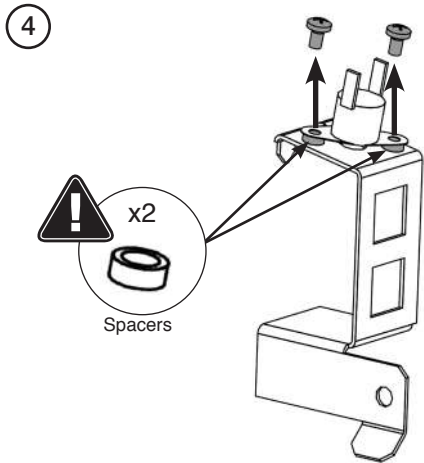

REFIT THE NEW SENSOR

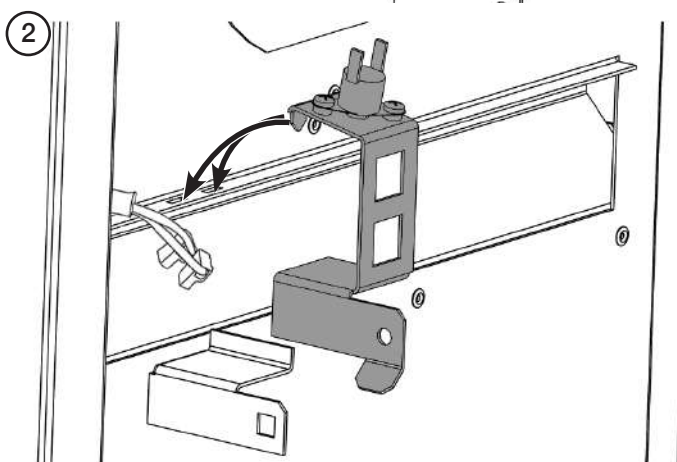
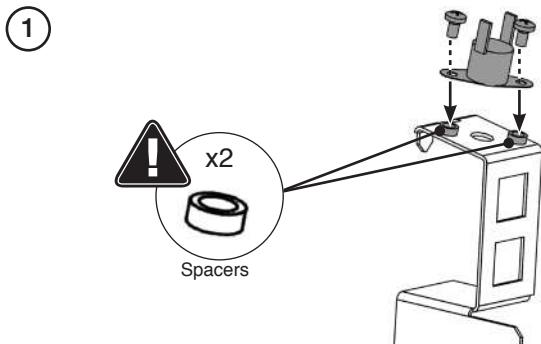

SPARES LIST - MAIN ASSEMBLY

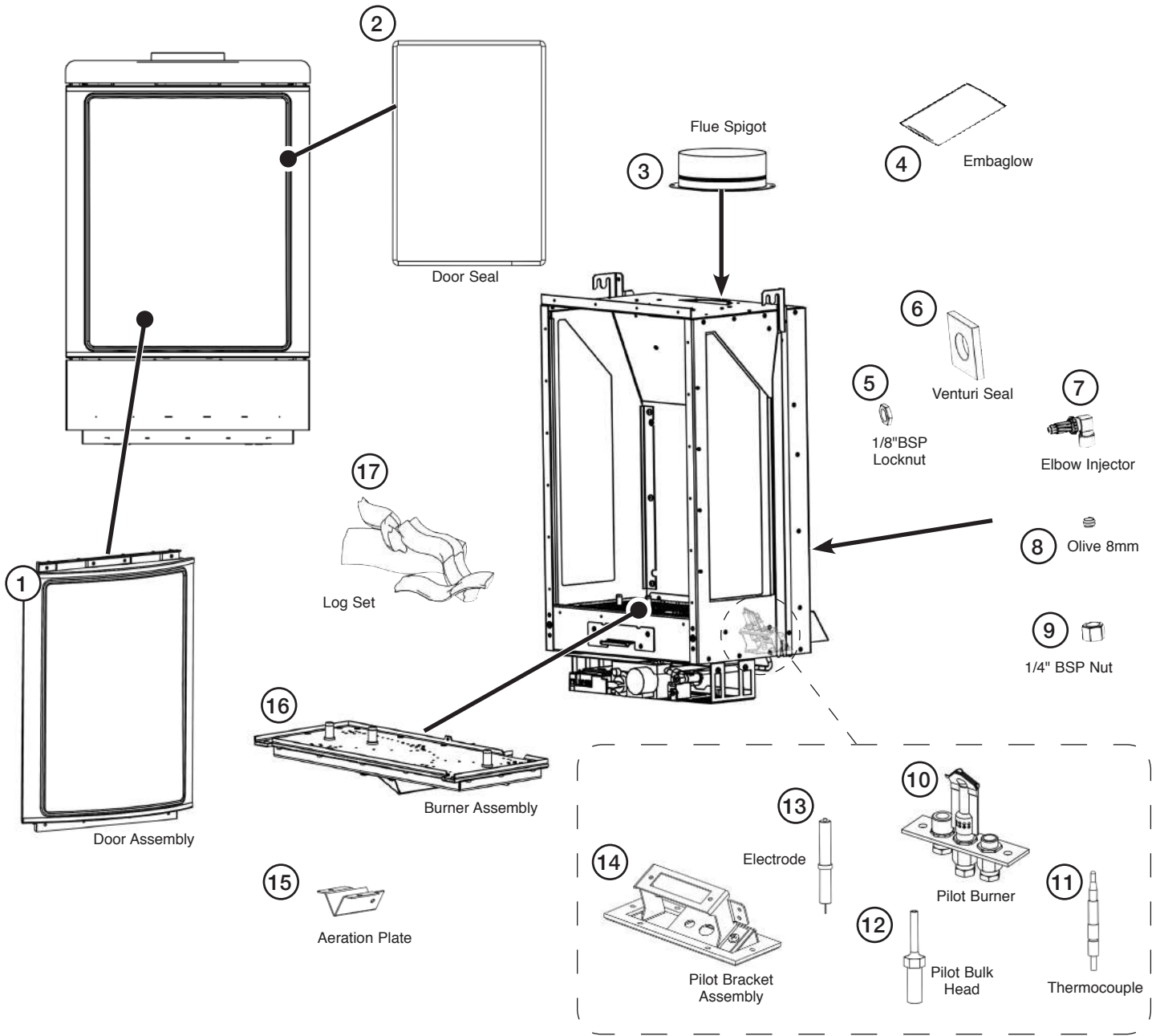

GAS TYPE	1	2	3	4	5	6	7	8	9	10	11
LPG	GZ14262	FA0726	MEC0033	GZ8471	FA0241	FA0171	IN0055	FA0011	FA0029	PI0070	PI0074
Nat. Gas							IN0023				

GAS TYPE	12	13	14	15	16	17
LPG	FA0723	PI0075	GZ13443	GZ11214	GZ14319	CE1755
Nat. Gas				GZ10406	GZ14318	



Due to continual technical improvements please check online or with your Onyx retailer for the most up to date parts lists.

Only use Genuine Onyx spares when servicing your appliance.
All of our essential spare parts and consumable items are available to purchase from our webshop at www.onyxspares.com.

SPARES LIST - CONTROL ASSEMBLY

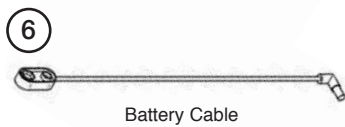
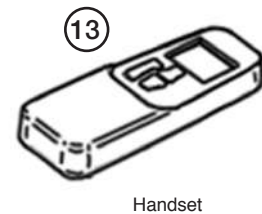
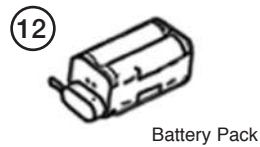
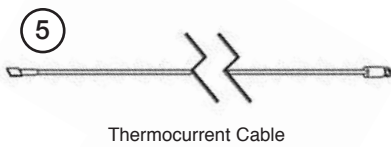
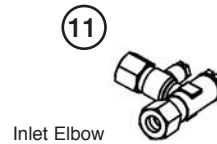
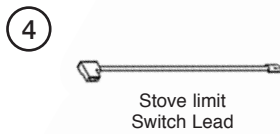
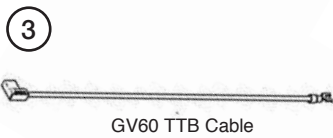
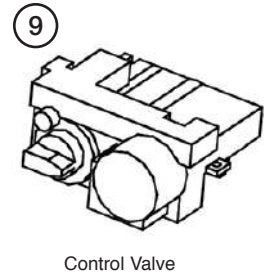
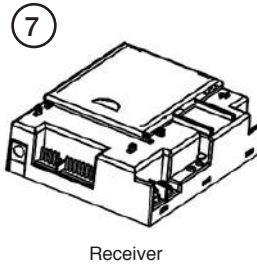
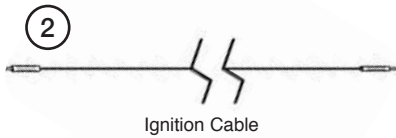
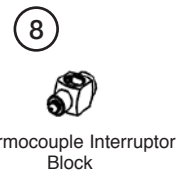
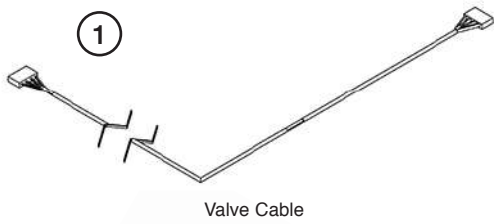

Model	1	2	3	4	5	6	7	8	9	10	11	12	13
Loft CF	GC0133	GC0125	EI0835	EL0670	EL0590	GC0146	EL0589	GC0124	GC0123K	GC0166	GC0095	EL0410	EL0571



Due to continual technical improvements please check online or with your Gazco retailer for the most up to date parts lists.

Only use Genuine Gazco spares when servicing your appliance.
All of our essential spare parts and consumable items are available to purchase from our webshop at www.gazcospares.com.

INFORMATION REQUIREMENT FOR GASEOUS FUEL LOCAL SPACE HEATER

Model	Loft 3 Sided Nat Gas	Loft 3 Sided LPG
Fuel	Space Heating Emissions (NOx) - mg / kWh _{input} (GCV)	130
Heat Output	Nominal Heat Output - P_{nom}	4.4kW
	Minimum Heat Output (indicative) - P_{min}	2.1kW
Auxiliary Electricity Consumption	At Nominal Heat Output - $e_{l_{max}}$	N/A
	At Minimum Heat Output - $e_{l_{min}}$	N/A
	In Standby Mode - $e_{l_{sb}}$	N/A
Useful Efficiency (NCV)	Useful Efficiency at nominal heat output - $\eta_{th,nom}$	78%
	Useful Efficiency at minimum heat output (indicative) - $\eta_{th,min}$	66%
Permanent Pilot Flame Power requirement	Permanent Pilot Flame Power requirement (if applicable) - P_{pilot}	0.200kW
Type of heat output/room temperature control		
	Electronic room temperature control + day timer	Yes
Other control options (multiple selections possible)		
	Room temperature control, with presence detection	No
	Room temperature control, with open window detection	No
	With distance control option	No
	With adaptive start control	No
	With working time limitation	No
	With black bulb sensor	No
Energy Efficiency Index		74%
Energy Efficiency Class		D
Contact:	Gazco Ltd, Osprey Road, Sowton Industrial Estate, Exeter, EX2 7JG	

PRODUCT MATERIAL INFORMATION

The following substances, preparations or components should be disposed of or recovered separately from other WEEE in compliance with Article 4 of EU Council Directive 75/442/EEC.

Metal	Steel	Can be taken to a local recycling centre for reuse to reduce waste going to landfill.
	Cast iron	
Glass		Can be taken to a local recycling centre for reuse to reduce waste going to landfill.
Vermiculite linings		Non hazardous material. Vermiculite can be crushed up and used for plant bedding and ash used for composting or disposed of at a local recycling centre for reuse to reduce waste going to landfill.
Rope seals/ Coal Fuel Effects/ Brick Effect, Ledgestone and Black Reed Liners		If the product contains any of the following: Rope seals, Coal Fuel Effects, Black Reed Brick Effect or Ledgestone Linings panels these items are made from Refractory Ceramic Fibre (RCF), a material which is commonly used for this application. Protective clothing is not required when handling these articles, but it is recommended to follow normal hygiene rules of not smoking, eating or drinking in the work area and always wash hands before eating or drinking. When servicing the appliance it is recommended that the replaced items are not broken up, but are sealed within heavy duty polythene bags and labelled as RCF waste. RCF waste is classed as stable, non-reactive hazardous waste and may be disposed of at a licensed landfill site.
Log Fuel Effects		Log Fuel effects are not considered hazardous to health, but are non-recyclable and must be disposed of in accordance to the rules in force.
Electrical components	(Fan kits etc if applicable)	Dispose of at a local recycling centre in accordance with the WEEE directive.

SERVICE RECORDS

1ST SERVICE

Date of Service.....
Next Service Due
Signed
Retailer's Stamp/GasSafe Registration Number

3RD SERVICE

Date of Service.....
Next Service Due
Signed
Retailer's Stamp/GasSafe Registration Number

5TH SERVICE

Date of Service.....
Next Service Due
Signed
Retailer's Stamp/GasSafe Registration Number

7TH SERVICE

Date of Service.....
Next Service Due
Signed
Retailer's Stamp/GasSafe Registration Number

9TH SERVICE

Date of Service.....
Next Service Due
Signed
Retailer's Stamp/GasSafe Registration Number

2ND SERVICE

Date of Service.....
Next Service Due
Signed
Retailer's Stamp/GasSafe Registration Number

4TH SERVICE

Date of Service.....
Next Service Due
Signed
Retailer's Stamp/GasSafe Registration Number

6TH SERVICE

Date of Service.....
Next Service Due
Signed
Retailer's Stamp/GasSafe Registration Number

8TH SERVICE

Date of Service.....
Next Due
Signed
Retailer's Stamp/Gas Safe Registration Number

10TH SERVICE

Date of Service.....
Next Service Due
Signed
Retailer's Stamp/GasSafe Registration Number

FOR ENQUIRIES IN THE U.K (EXCLUDING NI):

Gazco Ltd, Osprey Road, Sowton Industrial Estate, Exeter, Devon, England EX2 7JG

Tel: (01392) 261900 E-mail: info@gazco.com

FOR ENQUIRIES IN EUROPE (INCLUDING NI):

Stovax Heating Group (NI) Ltd (Comp reg NI675194), 40 Linenhall Street, Belfast, BT2 8BA

DX 400 NR Belfast Tel: +44 (0)1392 261990 E-mail: northernireland@gazco.com

